

USB97C202

SMSC USB2.0 to IDE Customer Evaluation Board

Design Details

Board:
UD-2215SMSC

Chip:
USB97C202

Board Form Factor:
Custom

SMSC Assy. 6320

Schematic Revision A

Circuit Diagrams utilizing SMSC Products Are Included As A Means Of Illustrating Typical Semiconductor Applications: Consequently Complete Information Sufficient For Construction Purposes Is Not Necessarily Given. The Information Has Been Carefully Checked And Is Believed To Be Entirely Reliable. However, No Responsibility Is Assumed For Inaccuracies. Furthermore, Such Information Does Not Convey To The Purchaser Of The Semiconductor Devices Described Any License Under The Patent Rights Of SMSC Or Others. SMSC Reserves The Right To Make Changes At Any Time In Order To Improve Design And Supply The Best Product Possible.

ITEM	Page(s)
Title Page	1
USB97C202	2
IDE Interface/ Serial EEPROM	3

		80 Arkay Drive PO Box 18047 Hauppauge, NY 11788-8847	
Title USB97C202 Low-Cost CRB			
Size C	Engineer	Assembly No. 6320	Rev A
Date: Tuesday, September 09, 2003		Sheet 1 of 3	

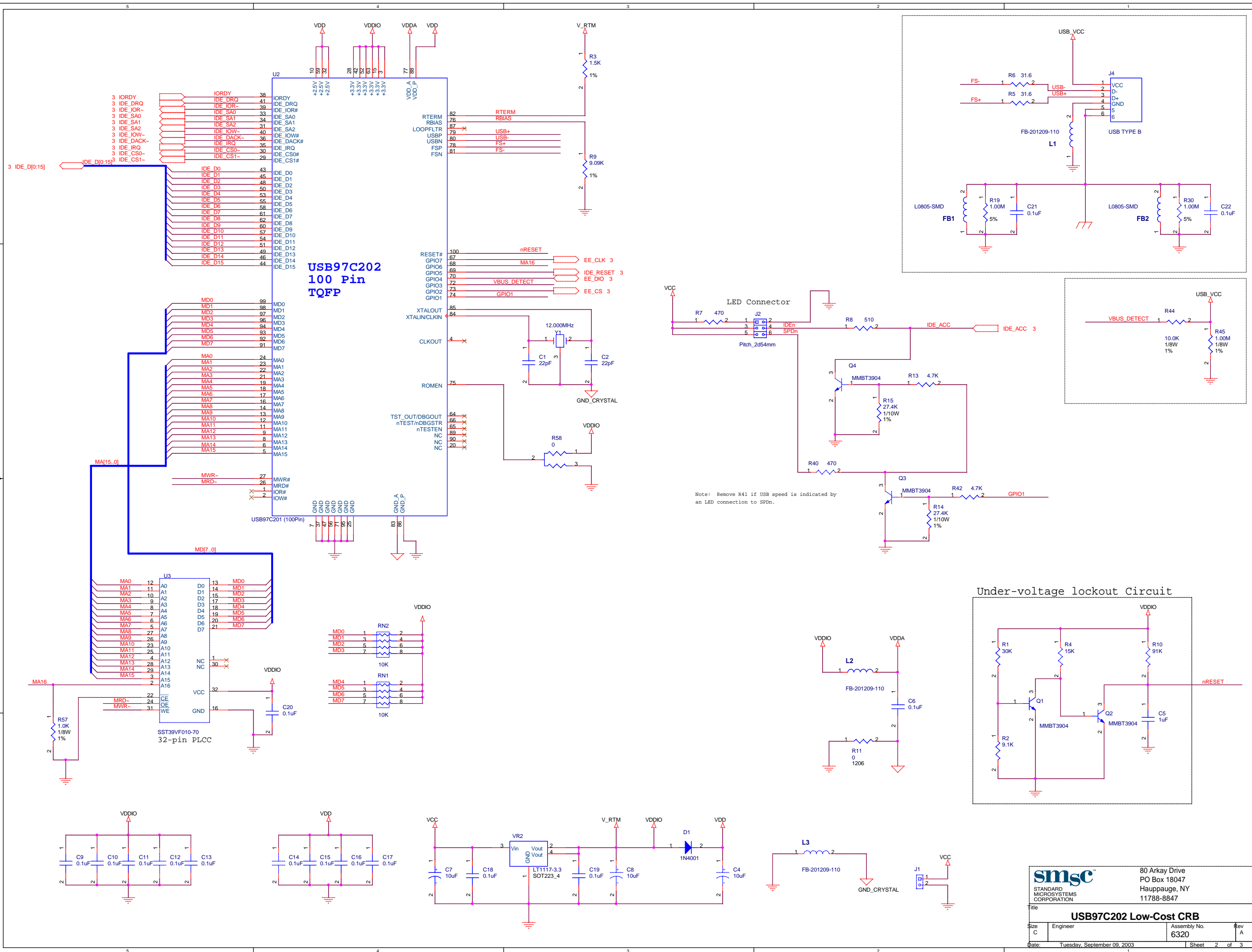

**USB97C202
100 Pin
TQFP**

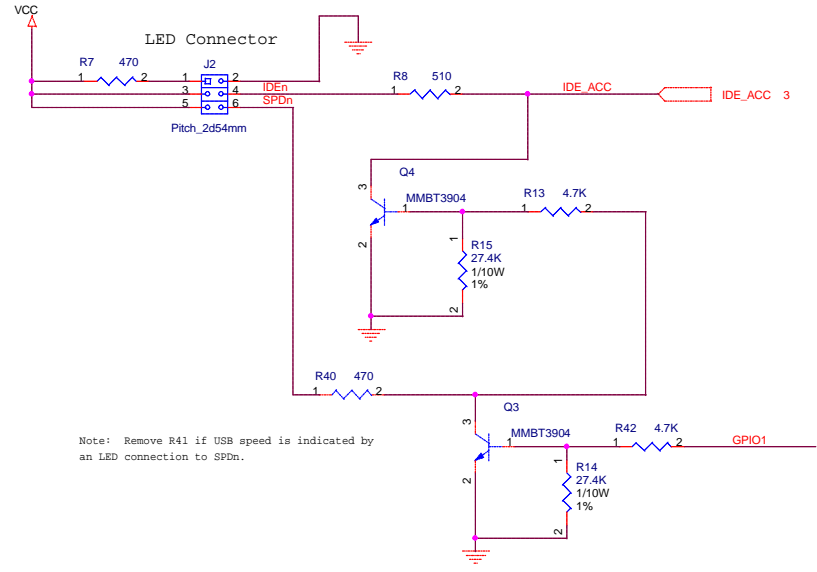
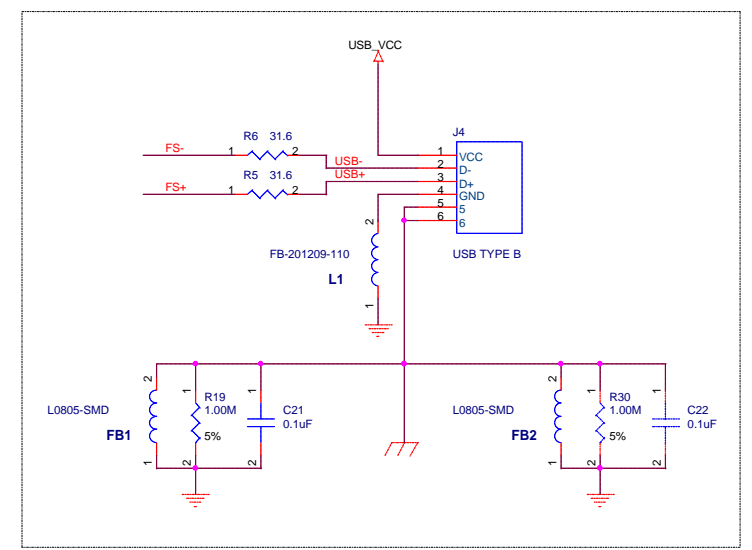

Note: Remove R41 if USB speed is indicated by an LED connection to SPDn.

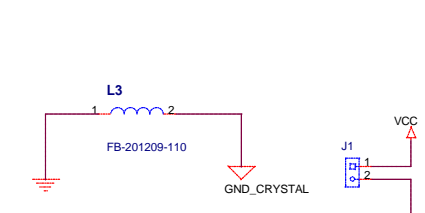
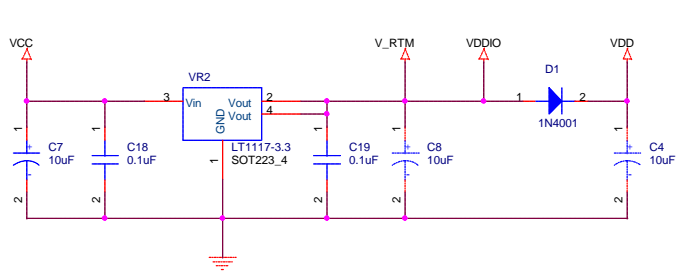
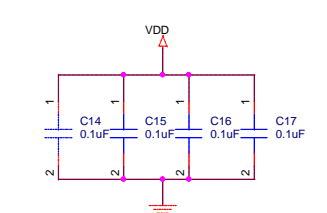
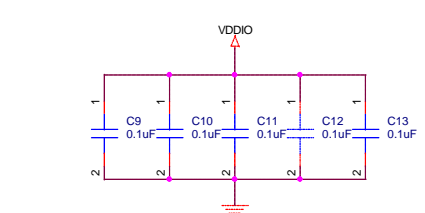
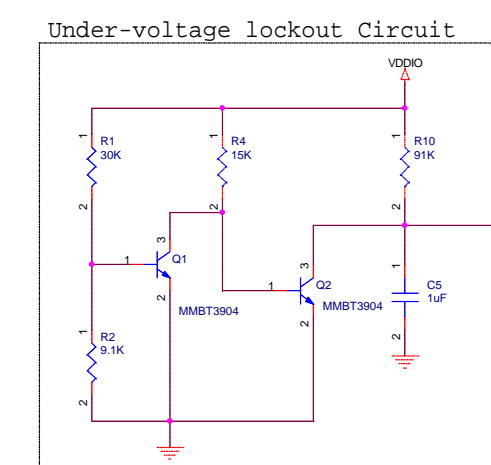
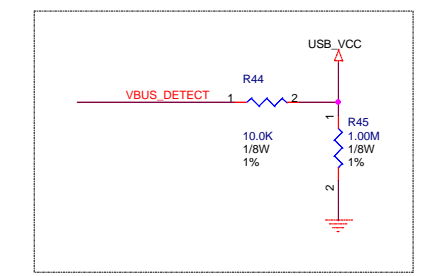

smc
 STANDARD MICROSYSTEMS CORPORATION
 80 Arky Drive
 PO Box 18047
 Hauppauge, NY
 11788-8847

USB97C202 Low-Cost CRB
 Title: USB97C202 Low-Cost CRB
 Size: C
 Engineer: [Blank]
 Assembly No.: 6320
 Date: Tuesday, September 09, 2003
 Sheet: 2 of 3

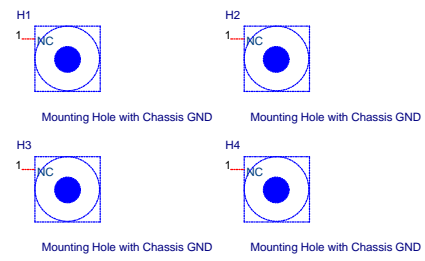
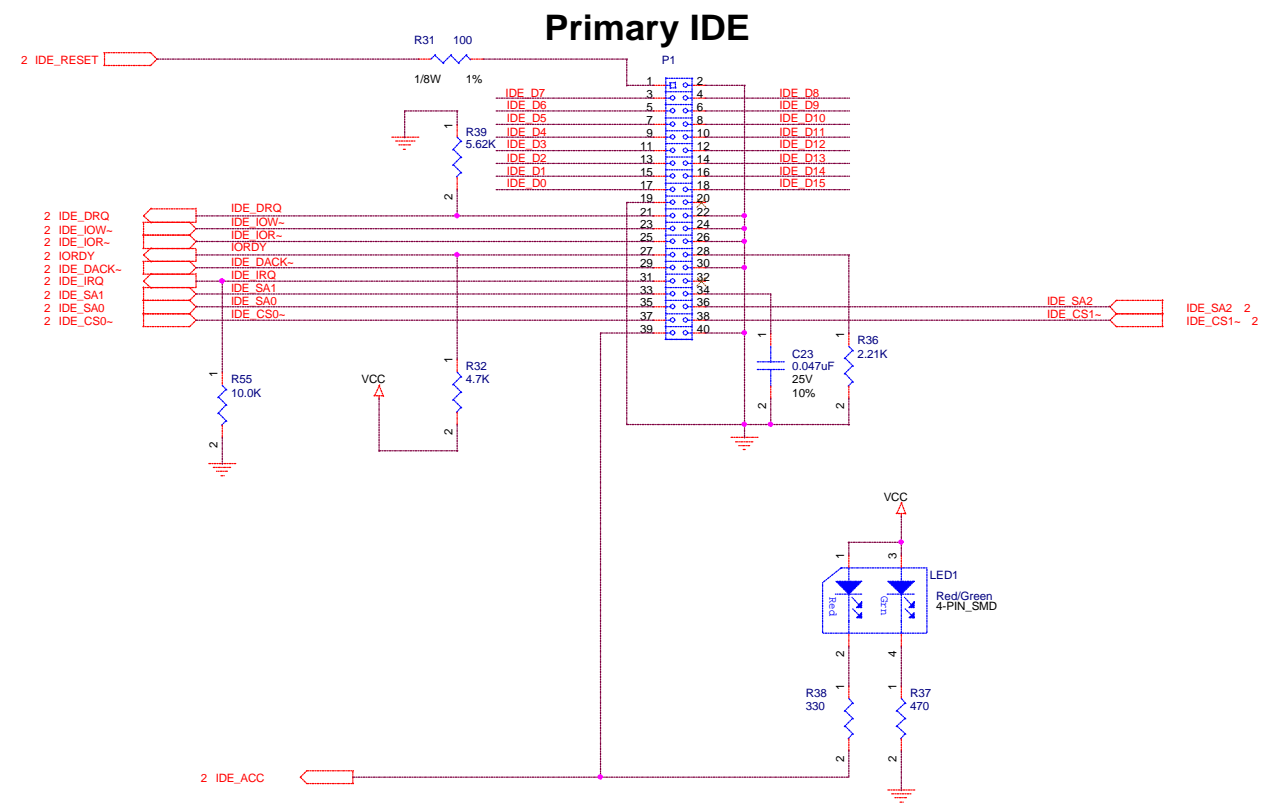
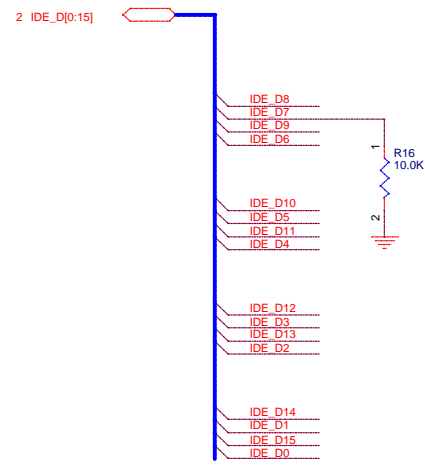

We suggest that EEPROM is an option component for USB device and the reason is as below:

The USB Mass Storage driver requires UNIQUE serial numbers for every drive in the system. For ATA drives, we can get this from the drive itself. But, there is no standard way to get it from an ATAPI drive.

Hence a unique serial number is required for each bridge board. Now this can't be in the program memory, BUT this would require EVERY ROM to be different. It's difficult to do in mass production, so by using a serial EEPROM this is overcome.

Also the EEPROM would store the Vendor ID/ Product ID/ etc. required to be different for each end customer

