



SYNTON-TECH CORPORATION

FUSIBLE RESISTORS

File No. : FRN-02

Version : B

Page : 1/21

Date : 2014.04.21

1. INTRODUCTION

There are some similarities between Resistors and Fuses in material and structure. Fusible Resistors contain both functions, as being resistor in normal condition and changed into fuse while abnormal current comes in protect machines and equipment. Since two functions performed by one resistor, the cost therefore saved. **SYNTON-TECH** fusible resistor series are produced with precision technique to get exact fusing time. It is also for telephone sets which demand 600V.

2. FEATURES

- It is suitable for protecting circuit boards.
- Small in size.
- Noncombustible insulating coat.
- Low temperature coefficient.
- Uniform in fusing time.
- Body coating is in gray or green, with 4 or 5 color bands or stamping.
- Too low or too high ohmic value can be supplied only case by case.

APPROVED	CHECKED	DESIGNED	REMARK	DOCUMENT NO.
Carol	May	Chen	RE: SGS	0201010025

Confidential, Do Not Disseminate.



SYNTON-TECH CORPORATION

FUSIBLE RESISTORS

File No. : FRN-02

Version : B

Page : 2/21

Date : 2014.04.21

3. EXPLANATIONS OF ORDERING CODE

DESCRIPTION : FRN 1/2W 5% 100Ω

SYNTON CODE : FRN 050 J 101 T

<u>SERIES</u>	<u>POWER</u>	<u>TOLERANCE</u>	<u>RESISTANCE</u>	<u>PACKAGE</u>
FUSIBLE RESISTOR FRN TYPE	012 : 1/8W 025 : 1/4W 050 : 1/2W 100 : 1W 200 : 2W 300 : 3W 500 : 5W 100[S] : 1W small Size 200[B] : 2W big Size (Please see detail of Figure1)	J : ±5% G : ±2% F : ±1%	<u>VALUE</u> E24 Series 3 Digits : 2R2 : 2.2Ω 101 : 100Ω 103 : 10K E96 Series 4 Digits : 2R20 : 2.2Ω 1000 : 100Ω 1002 : 10K (Please see detail of Figure7&8)	T=Tape Box S=Tape 26mm TR=Tape Reel B=Bulk M / MK / MB= Forming horizontal type F / FK / FKK= Forming vertical type (Please see detail of Figure4.5 & 6)



SYNTECH CORPORATION

FUSIBLE RESISTORS

File No. :	FRN-02
Version :	B
Page :	3/21
Date :	2014.04.21

4. ELECTRICAL CHARACTERISTICS

TYPE	FRN-12	FRN-25	FRN-33S	FRN-50S	FRN-50	FRN-100S	FRN-100	FRN-200S	FRN-200	FRN-300S	FRN-300	FRN-500S
Power Rating at 70°C	1/8W	1/4W	1/3W	1/2W	1/2W	1W	1W	2W	2W	3W	3W	5W
Operating Temp. Range	-55°C ~ +155°C											
Maximum Working Volt.	200V	200V	200V	250V	250V	300V	300V	350V	350V	350V	350V	350V
Maximum Overload Volt.	250V	300V	300V	350V	350V	450V	450V	500V	500V	500V	500V	500V
Dielectric withstanding Volt.	200V	250V	250V	300V	300V	350V	350V	400V	400V	400V	400V	400V
Value Range	STANDARD 1Ω~10KΩ										1Ω~100Ω	
	SPECIAL 0.1Ω~0.9Ω										0.1Ω~0.9Ω	
Temp. Coefficient	±300 ppm / °C											

Figure 1



5. POWER RATING

(1)**Power Derating** : The rated power at the temperature in excess of 70°C shall be derated in accordance with figure2

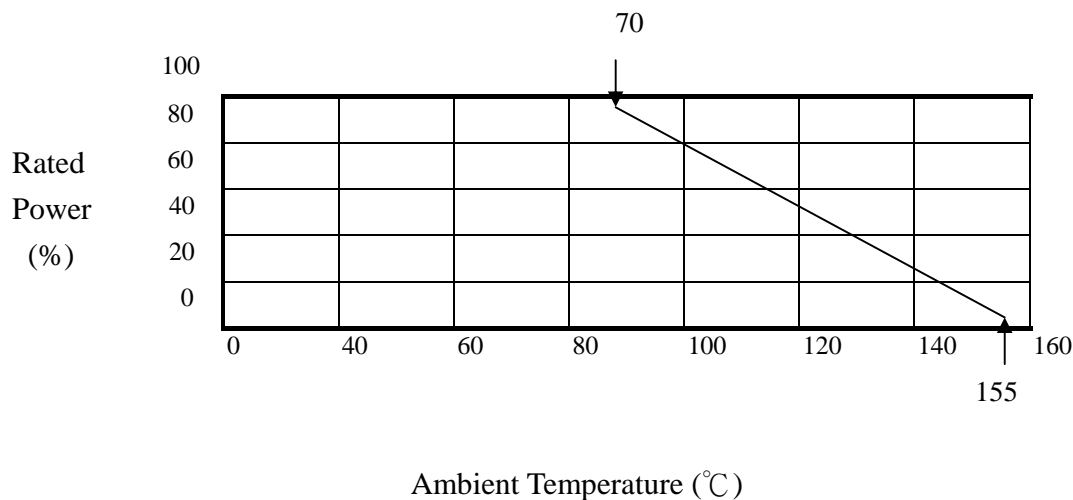

Figure2

(2)**Rated Voltage** : The DC or AC(rms) continuous working voltage corresponding to the rated power is determined by the following formula:

$$E = \sqrt{R \times P}$$

Where E : Continuous rated DC or AC (rms) working voltage (v)

P : Rated power (w)

R : Resistance value (Ω)



6. DIMENSIONS

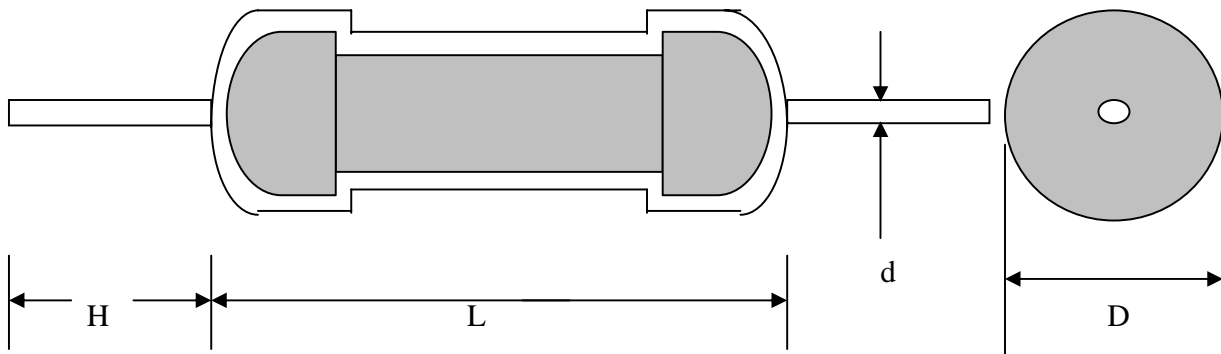

Unit:m/m

TYPE	POWER	L Max	D Max	H	d
FRN-12	1/8W	3.8	2.1	25 ± 3	0.43 ± 0.05
FRN-25	1/4W	6.8	2.5	25 ± 3	0.54 ± 0.1
FRN-33S	1/3W				
FRN-50S	1/2W	9.5	3.7	25 ± 3	0.58 ± 0.1
FRN-50	1/2W				
FRN-100S	1W	12	5.0	35 ± 3	0.75 ± 0.1
FRN-100	1W				
FRN-200S	2W	16	5.5	35 ± 3	0.75 ± 0.1
FRN-200	2W				
FRN-300S	3W	17.5	7	35 ± 3	0.75 ± 0.1
FRN-300	3W				
FRN-500S	5W				

Figure3



SYNTON-TECH CORPORATION

FUSIBLE RESISTORS

File No. :	FRN-02
Version :	B
Page :	6/21
Date :	2014.04.21

(1) FORMING PACKING

M / MK / MB= Forming horizontal type

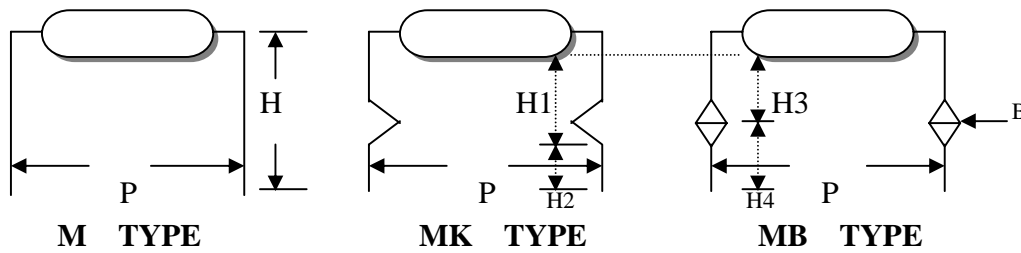

Unit : m/m

TYPE	POWER	FORMING Type	P ± 1	H ±2.5	H1 ± 1	H2 ± 1	H3 ± 1	H4 ± 1
FRN-25	1/4W	M	10~	5~	—	—	—	—
FRN-33S	1/3W	MK		—	8~	3~	—	—
FRN-50S	1/2W			—	—	—	—	—
FRN-50	1/2W	M	12.5~	10~	—	—	—	—
FRN-100S	1W	MK.MB		—	8~	3~	8~	5~
FRN-100	1W	M	15~	10~	—	—	—	—
FRN-200S	2W	MK.MB		—	8~	3~	8~	5~
FRN-200	2W	M	20~	10~	—	—	—	—
FRN-300S	3W	MK MB		—	8~	3~	8~	5~
FRN-300	3W	M	25~	10~	—	—	—	—
FRN-500S	5W	MK MB		—	6~	3~	6~	5~

Remark: 1. B = 1.15 ~

2. ALTERNATE MARKING METHOD ALSO AVAILABLE ON REQUEST.

Figure4



SYNTON-TECH CORPORATION
FUSIBLE RESISTORS

File No. : FRN-02
 Version : B
 Page : 7/21
 Date : 2014.04.21

(2) FORMING PACKING

F / FK / FKK=Forming vertical type

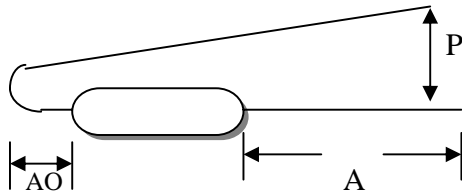

F TYPE

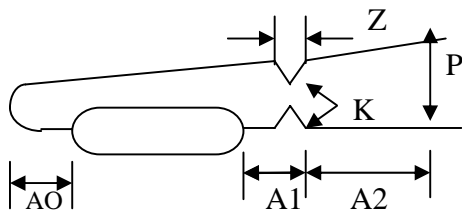

FKK TYPE

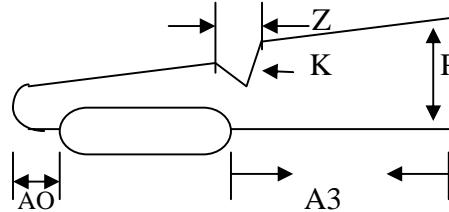

FK TYPE

Unit : m/m

TYPE	POWER	FORMING Type	P ± 1	A ± 1	A1 ± 1	A2 ± 1	A3 ± 1	A0 Max
FRN-25	1/4W	F	5~10	—	—	—	25±3	4.0
FRN-33S	1/3W	FK FKK	5~10	—	4	3	5~	4.0
FRN-50S	1/2W							
FRN-50 FRN-100S	1/2W 1W	F	5~10	5~	—	—	—	4.0
		FK	5~10	—	—	—	25±3	4.0
		FK FKK	5~10	—	4	3	5~	4.0
FRN-100 FRN-200S	1W 2W	F	5~10	5~	—	—	—	4.0
		FK FKK	5~10	—	4	3	5~	4.0
FRN-200 FRN-300S	2W 3W	F	5~10	5~	—	—	—	4.0
		FK FKK	5~10	—	4	3	5~	4.0
FRN-300 FRN-500S	3W 5W	F	5~10	5~	—	—	—	4.0
		FK FKK	5~10	5~	4	3	5~	4.0

Remark: 1. Z = 3 ±1. K = 2 ±0.5,

2. ALTERNATE MARKING METHOD ALSO AVAILABLE ON REQUEST.

Figure5



SYNTECH CORPORATION

FUSIBLE RESISTORS

File No. : FRN-02

Version : B

Page : 8/21

Date : 2014.04.21

(3) TAPE PACKING (T-TYPE)

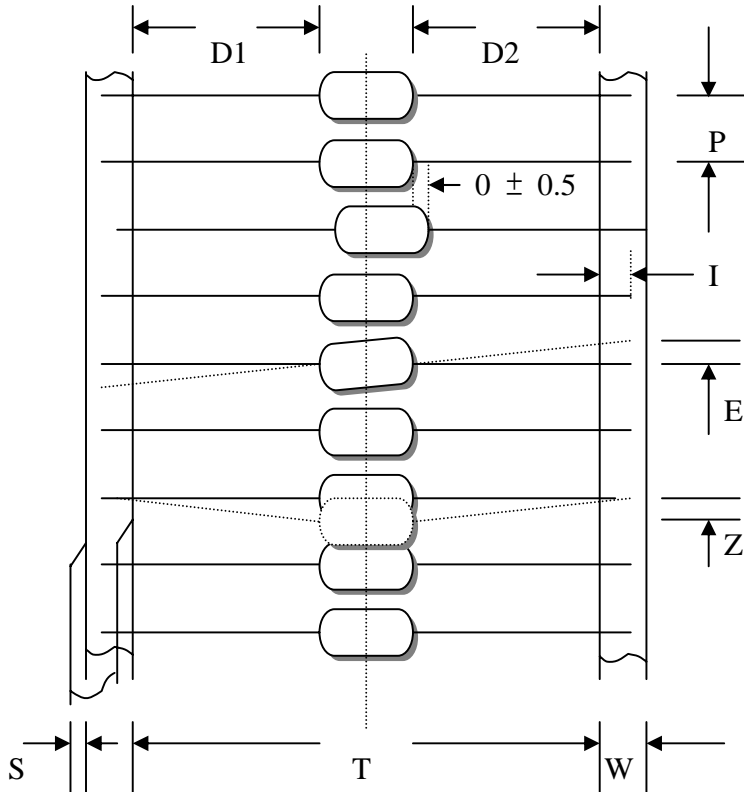

Unit:m/m

TYPE	SIZE	T	P ± 0.5	W ± 0.5	D1-D2 Max.	E Max.	Z Max.	S Max.	I Min.
FRN-25	T-26	26 ± 1.0	5	6	1.0	1	1.2	1	3
FRN-33S									
FRN-50S									
FRN-50	T-52	52 ± 2.0	5	6	1.0	1	1.2	1	3
FRN-100S									
FRN-100	T-74	74 ± 2.0	5	6	1.4	1	1.2	1	3
FRN-200S									
FRN-200	T-74	74 ± 2.0	10	6	1.4	1	1.2	1	3
FRN-300S									

Figure6



SYNTON-TECH CORPORATION
FUSIBLE RESISTORS

File No. :	FRN-02
Version :	B
Page :	9/21
Date :	2014.04.21

7. CHARACTERISTICS

(1) Resistance Temperature Characteristic

Test Method : -30°C ~ 150°C

Acceptance Standard : $\pm 300\text{ppm}/^\circ\text{C}$

(2) Temperature Cycling

Test Method : -30°C ~ 85°C for 5 Cycles

Acceptance Standard : $\pm (1\%+0.1\Omega)$

(3) Short-Time Overload

Test Method : 4 times of rated wattage for 5 sec.

Acceptance Standard : $\pm (2\%+0.1\Omega)$

(4) Resistance to Soldering Heat

Test Method : 350°C for 3 sec.

Acceptance Standard : $\pm (1\%+0.1\Omega)$

(5) Insulation Resistance

Test Method : 500V megger

Acceptance Standard : 1,000M Ω MIN.

(6) Load Life

Test Method : 70°C on-off cycle 1,000 hours.

Acceptance Standard : $\pm (5\%+0.1\Omega)$

(7) Solderability

Test Method : 260°C ± 5 for 3 ± 0.5 seconds

Acceptance Standard : 95% min. coverage



SYNTECH CORPORATION

FUSIBLE RESISTORS

File No. : FRN-02

Version : B

Page : 10/21

Date : 2014.04.21

(8) Moisture Load life

Test Method : 40°C 95% RH on-off cycle 1,000 hours.

Acceptance Standard : $\pm (5\%+0.1\Omega)$

(9) Fusing Characteristics

RESISTANCE RANGE	MAGNIFICATION OF POWER RATING	FUSING TIME
0.1 Ω ~ 0.2 Ω	RATED POWER X 64	60 Sec MAX
0.22 Ω ~ 1 Ω	RATED POWER X 32	
1.1 Ω ~ 2 Ω	RATED POWER X 25	
2.1 Ω ~ 10K Ω	RATED POWER X 16	

(10) Soldering Recommendation

Test Method : The Standard Length of epoxy on the terminal of our product is less than 1.5mm. Also, the Standard Welding Point must be over than 1.6mm from Resistor body.



SYNTECH CORPORATION
FUSIBLE RESISTORS

File No. :	FRN-02
Version :	B
Page :	11/21
Date :	2014.04.21

8. COLOR CODING

8.1 J (±5%)

**** Fusible type distinguish color code (WHITE)**

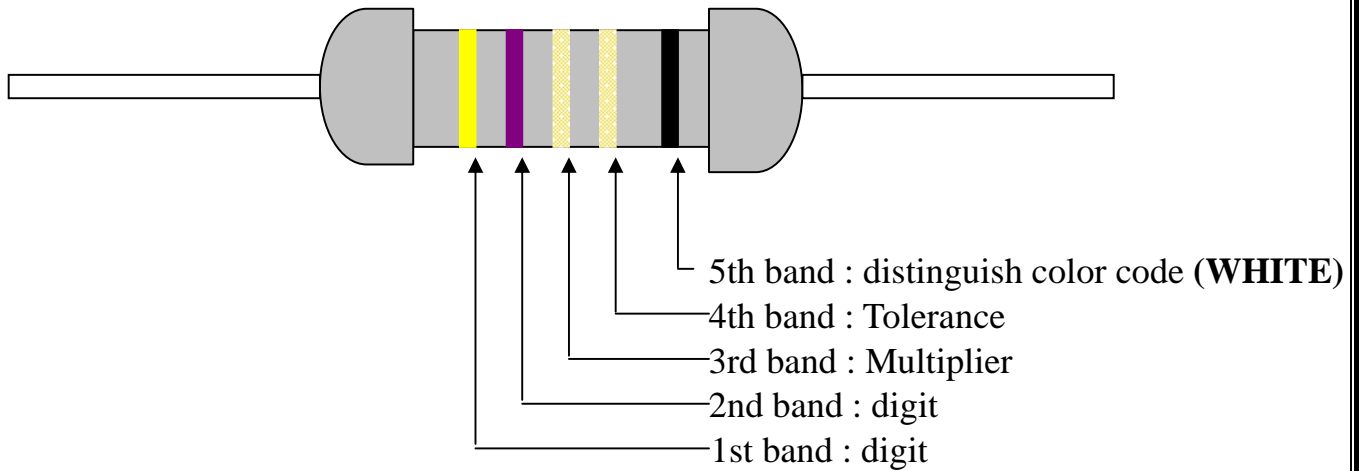

Color	1st, 2nd (Significant Figure)		3rd (Multiplier)	4th (Tolerance)	5th (Distinguish color code)
	1st	2nd			
Black	0	0	10^0	—	White
Brown	1	1	10^1	—	
Red	2	2	10^2	—	
Orange	3	3	10^3	—	
Yellow	4	4	10^4	—	
Green	5	5	10^5	—	
Blue	6	6	10^6	—	
Violet	7	7	10^7	—	
Gray	8	8	10^8	—	
White	9	9	10^9	—	
Gold	—	—	10^{-1}	J (±5%)	
Silver	—	—	10^{-2}	—	
Plain	—	—	10^{-3}	—	

Figure7



8.2 F (±1%) & G (±2%)

**** Fusible type distinguish color code (WHITE)**

**** Does not indicate the color code of tolerance**

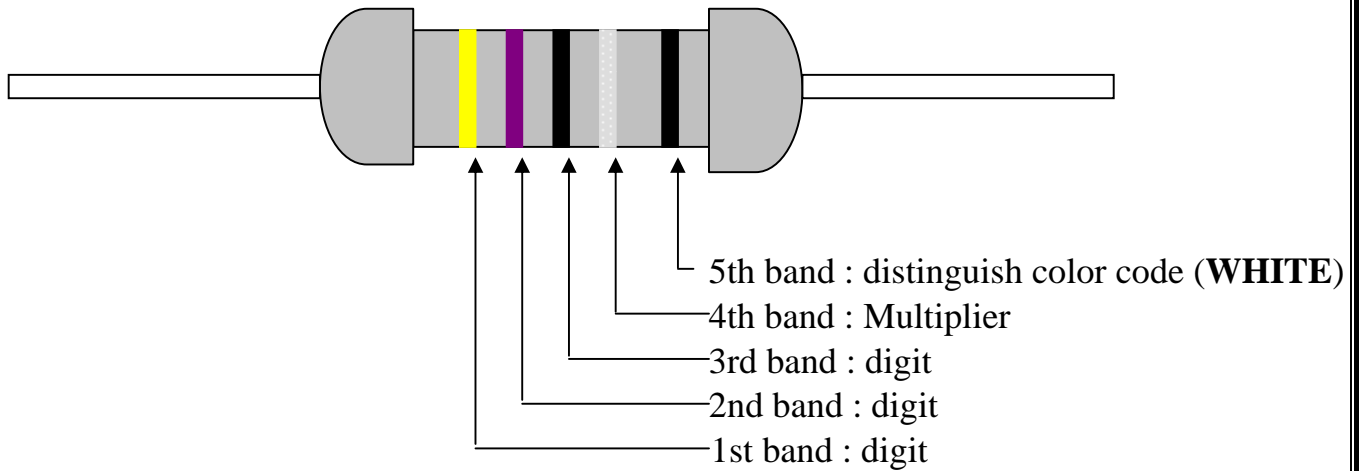

Color	1st, 2nd, 3rd (Significant Figure)			4th (Multiplier)	5th (Distinguish color code)
	1st	2nd	3rd		
Black	0	0	0	10^0	White
Brown	1	1	1	10^1	
Red	2	2	2	10^2	
Orange	3	3	3	10^3	
Yellow	4	4	4	10^4	
Green	5	5	5	10^5	
Blue	6	6	6	10^6	
Violet	7	7	7	10^7	
Gray	8	8	8	10^8	
White	9	9	9	10^9	
Gold	—	—	—	10^{-1}	
Silver	—	—	—	10^{-2}	
Plain	—	—	—	10^{-3}	

Figure8



SYNTECH CORPORATION

FUSIBLE RESISTORS

File No. :	FRN-02
Version :	B
Page :	13/21
Date :	2014.04.21



測試報告 Test Report

號碼(No.) : CE/2014/41231 日期(Date) : 2014/04/14 頁數(Page) : 1 of 9

欣統股份有限公司 / SYNTECH CORPORATION
 台灣省新北市汐止區新台五路一段79號16樓之3 (遠東世界中心)
 16F-3, NO. 79, FAR EAST WORLD CENTER SEC. 1, HSIN
 TAI WU ROAD, HSI-CHIH DIST., NEW TAIPEI CITY, TAIWAN
 (東莞欣統電子有限公司 / DONG GUAN SYNTECH CORPORATION)
 (廣東省東莞市大朗鎮水口村水常一路13號)
 (NO. 13, SHUICHANG FIRST ROAD, SHUIKOU VILLAGE,
 DALANG TOWN, DONGGUAN, GUANGDONG, CHINA)



以下測試樣品係由申請廠商所提供及確認 (The following sample(s) was/were submitted and identified by/on behalf of the applicant as) :

樣品名稱(Sample Description) : FUSIBLE RESISTORS(SILICON COATING)
 樣品型號(Style/Item No.) : FRN, FKN, FQP TYPE
 收件日期(Sample Receiving Date) : 2014/04/07
 測試期間(Testing Period) : 2014/04/07 TO 2014/04/14

測試需求(Test Requested) : (1) 依據客戶指定, 進行鎘、鉛、汞、六價鉻、多溴聯苯、多溴聯苯醚測試。(As specified by client, to test Cadmium, Lead, Mercury, Cr(VI), PBBs, PBDEs contents in the submitted sample.)

(2) 依據客戶指定, 進行全氟辛酸、全氟辛烷磺酸、鹵素-氟、氯、溴、碘測試。(As specified by client, to test PFOA, PFOS, Halogen-Fluorine, Chlorine, Bromine, Iodine contents in the submitted sample.)

測試方法(Test Method) : 請見下一頁 (Please refer to next pages).

測試結果(Test Results) : 請見下一頁 (Please refer to next pages).

Edison Chang / Sr. Supervisor
 Signed for and on behalf of
 SGS TAIWAN LTD.
 Chemical Laboratory – Taipei

This document is issued by the Company subject to its General Conditions of Service printed overleaf, available on request or accessible at <http://www.sgs.com/en/Terms-and-Conditions.aspx> and, for electronic format documents, subject to Terms and Conditions for Electronic Documents at <http://www.sgs.com/en/Terms-and-Conditions/Terms-and-Conditions.aspx>. Attention is drawn to the limitation of liability, indemnification and jurisdiction issues defined therein. Any holder of this document is advised that information contained herein reflects the Company's findings at the time of its intervention only and within the limits of Client's instructions, if any. The Company's sole responsibility is to its Client and this document does not exonerate parties to a transaction from exercising all their rights and obligations under the transaction documents. This document cannot be reproduced except in full, without prior written approval of the Company. Any unauthorized alteration, forgery or falsification of the content or appearance of this document is unlawful and offenders may be prosecuted to the fullest extent of the law. Unless otherwise stated the results shown in this test report refer only to the sample(s) tested.

SGS Taiwan Ltd. | 33, Wu Chuan Rd., New Taipei Industrial Park, New Taipei City, Taiwan / 新北市新北產業園區五權路33號
 台灣檢驗科技股份有限公司 | ☎ (886-2) 2299-3939 | ☎ (886-2) 2299-3237 | www.sgs.tw
 Member of SGS Group

TWB3320837

1001



SYNTECH CORPORATION

FUSIBLE RESISTORS

File No. : FRN-02
 Version : B
 Page : 14/21
 Date : 2014.04.21



測試報告 Test Report

號碼(No.) : CE/2014/41231 日期(Date) : 2014/04/14 頁數(Page) : 2 of 9

欣統股份有限公司 / SYNTECH CORPORATION
 台灣省新北市汐止區新台五路一段79號16樓之3 (遠東世界中心)
 16F-3, NO. 79, FAR EAST WORLD CENTER SEC. 1, HSIN
 TAI WU ROAD, HSI-CHIH DIST., NEW TAIPEI CITY, TAIWAN
 (東莞欣統電子有限公司 / DONG GUAN SYNTECH CORPORATION)
 (廣東省東莞市大朗鎮水口村水常一路13號)
 (NO. 13, SHUICHANG FIRST ROAD, SHUIKOU VILLAGE,
 DALANG TOWN, DONGGUAN, GUANGDONG, CHINA)



測試結果(Test Results)

測試部位(PART NAME) No.1 : 木體混測 (不含銀色金屬腳) (MIXED ALL PARTS OF BODY (EXCLUDING THE SILVER COLORED METAL PIN))

測試項目 (Test Items)	單位 (Unit)	測試方法 (Method)	方法值測 極限值 (MDL)	結果 (Result) No.1
鎘 / Cadmium (Cd)	mg/kg	參考IEC 62321-5: 2013方法, 以感應耦合 電漿原子發射光譜儀檢測。 / With reference to IEC 62321-5: 2013 and performed by ICP-AES.	2	n.d.
鉛 / Lead (Pb)	mg/kg		2	n.d.
汞 / Mercury (Hg)	mg/kg	參考IEC 62321-4: 2013方法, 以感應耦合 電漿原子發射光譜儀檢測。 / With reference to IEC 62321-4: 2013 and performed by ICP-AES.	2	n.d.
六價鉻 / Hexavalent Chromium Cr(VI)	mg/kg	參考IEC 62321: 2008方法, 以UV-VIS檢測。 / With reference to IEC 62321: 2008 and performed by UV-VIS.	2	n.d.
全氟辛烷磺酸 / Perfluorooctane sulfonates (PFOS-Acid, Metal Salt, Amide)	mg/kg	參考US EPA 3550C: 2007方法, 以液相層析 / 質譜儀檢測。 / With reference to US EPA 3550C: 2007. Analysis was performed by LC/MS.	10	n.d.
全氟辛酸 / PFOA (CAS No.: 335-67-1)	mg/kg		10	n.d.
鹵素 / Halogen				
鹵素 (氟) / Halogen-Fluorine (F) (CAS No.: 14762-94-8)	mg/kg	參考BS EN 14582:2007, 以離子層析儀分 析。 / With reference to BS EN 14582:2007. Analysis was performed by IC.	50	n.d.
鹵素 (氯) / Halogen-Chlorine (Cl) (CAS No.: 22537-15-1)	mg/kg		50	n.d.
鹵素 (溴) / Halogen-Bromine (Br) (CAS No.: 10097-32-2)	mg/kg		50	n.d.
鹵素 (碘) / Halogen-Iodine (I) (CAS No.: 14362-44-8)	mg/kg		50	n.d.

This document is issued by the Company subject to its General Conditions of Service printed overleaf, available on request or accessible at <http://www.sgs.com/en/Terms-and-Conditions.aspx> and, for electronic format documents, subject to Terms and Conditions for Electronic Documents at <http://www.sgs.com/en/Terms-and-Conditions/Terms-e-Documents.aspx>. Attention is drawn to the limitation of liability, indemnification and jurisdiction issues defined therein. Any holder of this document is advised that information contained herein reflects the Company's findings at the time of its intervention only and within the limits of Client's instructions, if any. The Company's sole responsibility is to its Client and this document does not exonerate parties to a transaction from exercising all their rights and obligations under the transaction documents. This document cannot be reproduced except in full, without prior written approval of the Company. Any unauthorized alteration, forgery or falsification of the content or appearance of this document is unlawful and offenders may be prosecuted to the fullest extent of the law. Unless otherwise stated the results shown in this test report refer only to the sample(s) tested.

TWB 3320838

SGS Taiwan Ltd. | 33, Wu Chuan Rd., New Taipei Industrial Park, New Taipei City, Taiwan / 新北市新北產業園區五權路33號
 台灣檢驗科技股份有限公司 | (0886-2) 7299-3039 | (0886-2) 7299-3237 | www.sgs.tw
 Member of SGS Group

1001



SYNTECH CORPORATION

FUSIBLE RESISTORS

File No. : FRN-02
 Version : B
 Page : 15/21
 Date : 2014.04.21



測試報告 Test Report

號碼(No.) : CE/2014/41231 日期(Date) : 2014/04/14 頁數(Page) : 3 of 9

欣統股份有限公司 / SYNTECH CORPORATION
 台灣省新北市汐止區新台五路一段79號16樓之3 (遠東世界中心)
 16F-3, NO. 79, FAR EAST WORLD CENTER SEC. 1, HSI
 TAI WU ROAD, HSI-CHIH DIST., NEW TAIPEI CITY, TAIWAN
 (東莞欣統電子有限公司 / DONG GUAN SYNTECH CORPORATION)
 (廣東省東莞市大朗鎮水口村水常一路13號)
 (NO. 13, SHUICHANG FIRST ROAD, SHUIKOU VILLAGE,
 DALANG TOWN, DONGGUAN, GUANGDONG, CHINA)



測試項目 (Test Items)	單位 (Unit)	測試方法 (Method)	方法偵測 極限值 (MDL)	結果 (Result) No. 1
多溴聯苯總和 / Sum of PBBs	mg/kg	參考 IEC 62321: 2008 方法, 以氣相層析/質譜儀檢測。 / With reference to IEC 62321: 2008 and performed by GC/MS.	-	n.d.
一溴聯苯 / Monobromobiphenyl			5	n.d.
二溴聯苯 / Dibromobiphenyl			5	n.d.
三溴聯苯 / Tribromobiphenyl			5	n.d.
四溴聯苯 / Tetrabromobiphenyl			5	n.d.
五溴聯苯 / Pentabromobiphenyl			5	n.d.
六溴聯苯 / Hexabromobiphenyl			5	n.d.
七溴聯苯 / Heptabromobiphenyl			5	n.d.
八溴聯苯 / Octabromobiphenyl			5	n.d.
九溴聯苯 / Nonabromobiphenyl			5	n.d.
十溴聯苯 / Decabromobiphenyl			5	n.d.
多溴聯苯醚總和 / Sum of PBDEs			-	n.d.
一溴聯苯醚 / Monobromodiphenyl ether			5	n.d.
二溴聯苯醚 / Dibromodiphenyl ether			5	n.d.
三溴聯苯醚 / Tribromodiphenyl ether			5	n.d.
四溴聯苯醚 / Tetrabromodiphenyl ether			5	n.d.
五溴聯苯醚 / Pentabromodiphenyl ether			5	n.d.
六溴聯苯醚 / Hexabromodiphenyl ether			5	n.d.
七溴聯苯醚 / Heptabromodiphenyl ether			5	n.d.
八溴聯苯醚 / Octabromodiphenyl ether			5	n.d.
九溴聯苯醚 / Nonabromodiphenyl ether	5	n.d.		
十溴聯苯醚 / Decabromodiphenyl ether	5	n.d.		

This document is issued by the Company subject to its General Conditions of Service printed overleaf, available on request or accessible at <http://www.sgs.com.tw/Terms-and-Conditions.aspx> and for electronic format documents, subject to Terms and Conditions for Electronic Documents at <http://www.sgs.com.tw/Terms-and-Conditions/Terms-for-Electronic-Documents.aspx>. Attention is drawn to the limitation of liability, indemnification and jurisdiction issues defined therein. Any holder of this document is advised that information contained hereon reflects the Company's findings at the time of its intervention only and within the limits of Client's instructions, if any. The Company's sole responsibility is to its Client and this document does not exonerate parties to a transaction from exercising all their rights and obligations under the transaction documents. This document cannot be reproduced except in full, without prior written approval of the Company. Any unauthorized alteration, forgery or falsification of the content or appearance of this document is unlawful and offenders may be prosecuted to the fullest extent of the law. Unless otherwise stated the results shown in this test report refer only to the sample(s) tested.

TWB3320839

SGS Taiwan Ltd. | 33, Wu Chuan Rd., New Taipei Industrial Park, New Taipei City, Taiwan / 新北市新莊區五權路33號
 台灣檢驗科技股份有限公司 | t (086-2) 2299-3939 | f (086-2) 2299-3237 | www.sgs.tw

Member of SRII Group

1001



SYNTON-TECH CORPORATION

FUSIBLE RESISTORS

File No. :	FRN-02
Version :	B
Page :	16/21
Date :	2014.04.21



測試報告

Test Report

號碼(No.) : CE/2014/41231 日期(Date) : 2014/04/14 頁數(Page) : 4 of 9

欣統股份有限公司 / SYNTON-TECH CORPORATION
 台灣省新北市汐止區新台五路一段79號16樓之3 (遠東世界中心)
 16F-3, NO. 79, FAR EAST WORLD CENTER SEC. 1, HSIN
 TAI WU ROAD, HSI-CHIH DIST., NEW TAIPEI CITY, TAIWAN
 (東莞欣統電子有限公司 / DONG GUAN SYNTON-TECH CORPORATION)
 (廣東省東莞市大朗鎮水口村水常一路13號)
 (NO. 13, SHUICHIANG FIRST ROAD, SHUIKOU VILLAGE,
 DALANG TOWN, DONGGUAN, GUANGDONG, CHINA)



備註(Note) :

1. mg/kg = ppm ; 0.1wt% = 1000ppm
2. n.d. = Not Detected (未檢出)
3. MDL = Method Detection Limit (方法偵測極限值)
4. "-" = Not Regulated (無規格值)
5. 樣品的測試是基於申請人要求混合測試，報告中的混合測試結果不代表其中個別單一材質的含量。
 (The samples was/were analyzed on behalf of the applicant as mixing sample in one testing. The above results was/were only given as the informality value.)

PFOS參考資訊(Reference Information) : 持久性有機污染物 POPs - (EU) 757/2010

PFOS濃度在物質或製備中不得超過0.001%(10ppm)，在半成品、成品或零部件中不得超過0.1%(1000ppm)，在紡織品或塗層材料中不得超過1µg/m²。(Outlawing PFOS as substances or preparations in concentrations above 0.001% (10ppm), in semi-finished products or articles or parts at a level above 0.1%(1000ppm), in textiles or other coated materials above 1µg/m².)

This document is issued by the Company subject to its General Conditions of Service printed overleaf, available on request or accessible at <http://www.sgs.com/en/Terms-and-Conditions.aspx> and, for electronic format documents, subject to Terms and Conditions for Electronic Documents at <http://www.sgs.com/en/Terms-and-Conditions/Terms-e-Documents.aspx>. Attention is drawn to the limitation of liability, indemnification and jurisdiction issues defined therein. Any holder of this document is advised that information contained herein reflects the Company's findings at the time of its intervention only and within the limits of Client's instructions, if any. The Company's sole responsibility is to its Client and this document does not exonerate parties to a transaction from exercising all their rights and obligations under the transaction documents. This document cannot be reproduced except in full, without prior written approval of the Company. Any unauthorized alteration, forgery or falsification of the content or appearance of this document is unlawful and offenders may be prosecuted to the fullest extent of the law. Unless otherwise stated the results shown in this test report refer only to the sample(s) tested.

SGS Taiwan Ltd.
 台灣檢驗科技股份有限公司

33, Wu Chuan Rd., New Taipei Industrial Park, New Taipei City, Taiwan / 新北市新北產業園區五權路33號
 ☎ (886 2) 2299-3939 ☎ (886 2) 2299-3232 www.sgs.tw

Member of SGS Group

TWB3320840

1001



SYNTECH CORPORATION

FUSIBLE RESISTORS

File No. : FRN-02
Version : B
Page : 17/21
Date : 2014.04.21



測試報告 Test Report

號碼(No.) : CR/2014/41231 日期(Date) : 2014/04/14 頁數(Page) : 5 of 9

欣統股份有限公司 / SYNTECH CORPORATION
台灣省新北市汐止區新台五路一段79號16樓之3 (遠東世界中心)
16F-3, NO. 79, FAR EAST WORLD CENTER SEC. 1, HSIN
TAI WU ROAD, HSI-CHIH DIST., NEW TAIPEI CITY, TAIWAN
(東莞欣統電子有限公司 / DONG GUAN SYNTECH CORPORATION)
(廣東省東莞市大朗鎮水口村水常一路13號)
(NO. 13, SHUICHANG FIRST ROAD, SHUIKOU VILLAGE,
DALANG TOWN, DONGGUAN, GUANGDONG, CHINA)



- 1) 根據以下的流程圖之條件，樣品已完全溶解。(六價鉻測試方法除外) / These samples were dissolved totally by pre-conditioning method according to below flow chart. (Cr⁶⁺ test method excluded)
- 2) 測試人員：楊登偉 / Name of the person who made measurement: Climbgreat Yang
- 3) 測試負責人：張啓興 / Name of the person in charge of measurement: Troy Chang

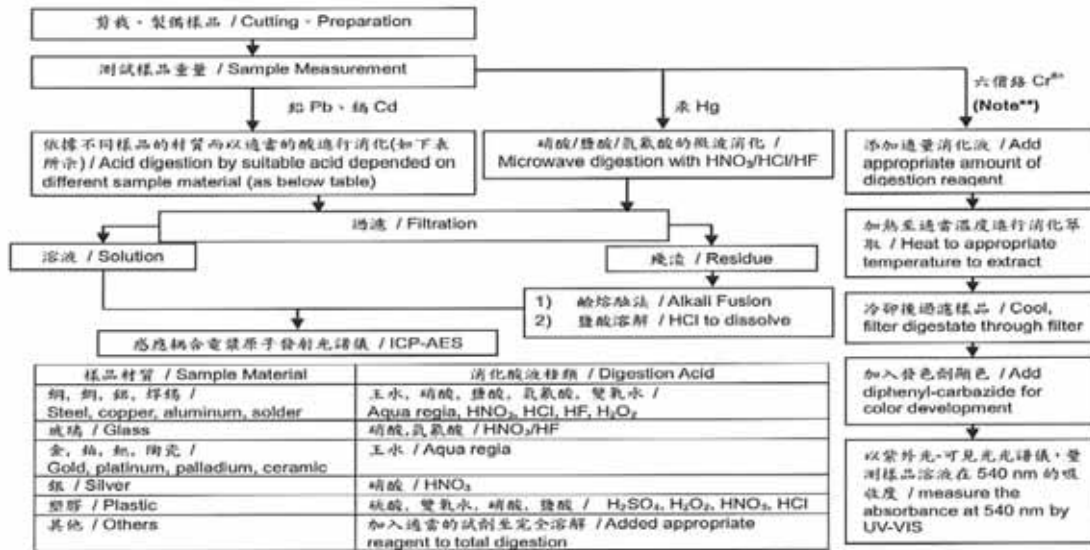

- (1) 針對非金屬材料加入鹼性消化液，加熱至 90-95°C 萃取。 / For non-metallic material, add alkaline digestion reagent and heat to 90-95°C.
- (2) 針對金屬材料加入純水，加熱至沸騰萃取。 / For metallic material, add pure water and heat to boiling.

This document is issued by the Company subject to its General Conditions of Service printed overleaf, available on request or accessible at <http://www.sgs.com/en/Terms-and-Conditions.aspx> and, for electronic format documents, subject to Terms and Conditions for Electronic Documents at http://www.sgs.com/en/Terms-and-Conditions/terms_e-Document.aspx. Attention is drawn to the limitation of liability, indemnification and jurisdiction issues defined therein. Any holder of this document is advised that information contained hereon reflects the Company's findings at the time of its intervention only and within the limits of Client's instructions, if any. The Company's sole responsibility is to its Client and this document does not exonerate parties to a transaction from exercising all their rights and obligations under the transaction documents. This document cannot be reproduced except in full, without prior written approval of the Company. Any unauthorized alteration, forgery or falsification of the content or appearance of this document is unlawful and offenders may be prosecuted to the fullest extent of the law. Unless otherwise stated the results shown in this test report refer only to the sample(s) tested.

TWB3320841

SGS Taiwan Ltd.
台灣檢驗科技股份有限公司

33, Wu Chuan Rd., New Taipei Industrial Park, New Taipei City, Taiwan / 新北市新莊區五權路33號
☎ (886 2) 2288 3838 ☎ (886 2) 2289 3237

www.sgs.tw
Member of SGS Group

1001



SYNTON-TECH CORPORATION

FUSIBLE RESISTORS

File No. :	FRN-02
Version :	B
Page :	18/21
Date :	2014.04.21



測試報告 Test Report

號碼(No.) : CE/2014/41231 日期(Date) : 2014/04/14 頁數(Page) : 6 of 9

欣統股份有限公司 / SYNTON-TECH CORPORATION
 台灣省新北市汐止區新台五路一段79號16樓之3 (遠東世界中心)
 16F-3, NO. 79, FAR EAST WORLD CENTER SEC. 1, HSIN
 TAI WU ROAD, HSI-CHIH DIST., NEW TAIPEI CITY, TAIWAN
 (東莞欣統電子有限公司 / DONG GUAN SYNTON-TECH CORPORATION)
 (廣東省東莞市大朗鎮水口村水常一路13號)
 (NO. 13, SHUICHANG FIRST ROAD, SHUIKOU VILLAGE,
 DALANG TOWN, DONGGUAN, GUANGDONG, CHINA)



多溴聯苯/多溴聯苯醚分析流程圖 / PBB/PBDE analytical FLOW CHART

- 測試人員：翁錫彬 / Name of the person who made measurement: Roman Wong
- 測試負責人：張啓興 / Name of the person in charge of measurement: Troy Chang
- 初次測試程序 / First testing process →
- 選擇性篩檢程序 / Optional screen process ······
- 確認程序 / Confirmation process - - - ->

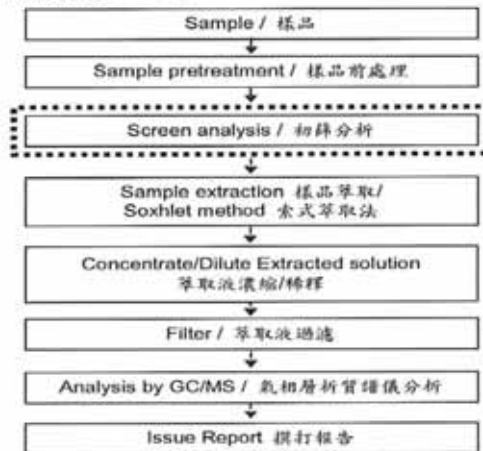

This document is issued by the Company subject to its General Conditions of Service printed overleaf, available on request or accessible at <http://www.sgs.com/en/Terms-and-Conditions.aspx> and, for electronic format documents, subject to Terms and Conditions for Electronic Documents at http://www.sgs.com/en/Terms-and-Conditions/Terms_e-Documents.aspx. Attention is drawn to the limitation of liability, indemnification and jurisdiction issues defined therein. Any holder of this document is advised that information contained hereon reflects the Company's findings at the time of its intervention only and within the limits of Client's instructions, if any. The Company's sole responsibility is to its Client and this document does not exonerate parties to a transaction from exercising all their rights and obligations under the transaction documents. This document cannot be reproduced except in full, without prior written approval of the Company. Any unauthorized alteration, forgery or falsification of the content or appearance of this document is unlawful and offenders may be prosecuted to the fullest extent of the law. Unless otherwise stated the results shown in this test report refer only to the sample(s) tested.

SGS Taiwan Ltd. | 33, Wu Chuan Rd., New Taipei Industrial Park, New Taipei City, Taiwan / 新北市新莊區五權路33號
 台灣檢驗科技股份有限公司 | (886-2) 2299-3939 | (886-2) 2299-3237 | www.sgs.tw
 Member of SGS Group

TW63320842

1001



SYNTECH CORPORATION

FUSIBLE RESISTORS

File No. :	FRN-02
Version :	B
Page :	19/21
Date :	2014.04.21



測試報告 Test Report

號碼(No.) : CE/2014/41231 日期(Date) : 2014/04/14 頁數(Page) : 7 of 9

欣統股份有限公司 / SYNTECH CORPORATION
 台灣省新北市汐止區新台五路一段79號16樓之3 (遠東世界中心)
 16F-3, NO. 79, FAR EAST WORLD CENTER SEC. 1, HSIN
 TAI WU ROAD, HSI-CHIH DIST., NEW TAIPEI CITY, TAIWAN
 (東莞欣統電子有限公司 / DONG GUAN SYNTECH CORPORATION)
 (廣東省東莞市大朗鎮水口村水常一路13號)
 (NO. 13, SHUICHANG FIRST ROAD, SHUIKOU VILLAGE,
 DALANG TOWN, DONGGUAN, GUANGDONG, CHINA)



鹵素分析流程圖 / Analytical flow chart of halogen content

- 測試人員：陳思臻 / Name of the person who made measurement: Rita Chen
- 測試負責人：張啓興 / Name of the person in charge of measurement: Troy Chang

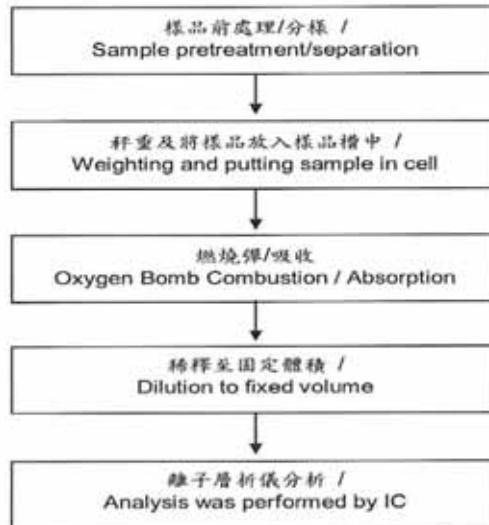

This document is issued by the Company subject to its General Conditions of Service printed overleaf, available on request or accessible at <http://www.sgs.com/en/Terms-and-Conditions.aspx> and, for electronic format documents, subject to Terms and Conditions for Electronic Documents at <http://www.sgs.com/en/Terms-and-Conditions/ElectronicDocuments.aspx>. Attention is drawn to the limitation of liability, indemnification and jurisdiction issues defined therein. Any holder of this document is advised that information contained hereon reflects the Company's findings at the time of its intervention only and within the limits of Client's instructions, if any. The Company's sole responsibility is to its Client and this document does not exonerate parties to a transaction from exercising all their rights and obligations under the transaction documents. This document cannot be reproduced except in full, without prior written approval of the Company. Any unauthorized alteration, forgery or falsification of the content or appearance of this document is unlawful and offenders may be prosecuted to the fullest extent of the law. Unless otherwise stated the results shown in this test report refer only to the sample(s) tested.

TWB3320843

SGS Taiwan Ltd. | 33, Wu Chuen Rd., New Taipei Industrial Park, New Taipei City, Taiwan / 新北市新北產業園區五權路33號
 台灣檢驗科技股份有限公司 | (886-2) 2299-3939 | (886-2) 2299-3232 | www.sgs.tw

Member of SGS Group

1001



SYNTECH CORPORATION

FUSIBLE RESISTORS

File No. :	FRN-02
Version :	B
Page :	20/21
Date :	2014.04.21



測試報告 Test Report

號碼(No.) : CE/2014/41231 日期(Date) : 2014/04/14 頁數(Page) : 8 of 9

欣統股份有限公司 / SYNTECH CORPORATION
 台灣省新北市汐止區新台五路一段79號16樓之3 (遠東世界中心)
 16F-3, NO. 79, FAR EAST WORLD CENTER SEC. 1, HSIN
 TAI WU ROAD, HSI-CHIH DIST., NEW TAIPEI CITY, TAIWAN
 (東莞欣統電子有限公司 / DONG GUAN SYNTECH CORPORATION)
 (廣東省東莞市大朗鎮水口村水常一路13號)
 (NO. 13, SHUICHANG FIRST ROAD, SHUIKOU VILLAGE,
 DALANG TOWN, DONGGUAN, GUANGDONG, CHINA)



全氟辛酸/全氟辛烷磺酸分析流程圖 / PFOA/PFOS analytical flow chart

- 測試人員: 翁賜彬 / Name of the person who made measurement: Roman Wong
- 測試負責人: 張啓興 / Name of the person in charge of measurement: Troy Chang

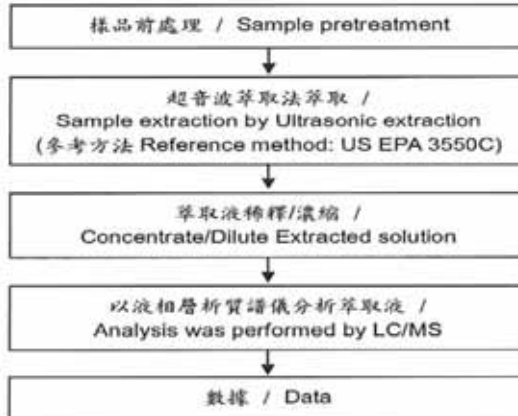

This document is issued by the Company subject to its General Conditions of Service printed overleaf, available on request or accessible at <http://www.sgs.com.tw/Terms-and-Conditions.aspx> and, for electronic format documents, subject to Terms and Conditions for Electronic Documents at <http://www.sgs.com.tw/Terms-and-Conditions/Terms-and-Conditions.aspx>. Attention is drawn to the limitation of liability, indemnification and jurisdiction issues defined therein. Any holder of this document is advised that information contained herein reflects the Company's findings at the time of its intervention only and within the limits of Client's instructions, if any. The Company's sole responsibility is to its Client and this document does not exonerate parties to a transaction from exercising all their rights and obligations under the transaction documents. This document cannot be reproduced except in full, without prior written approval of the Company. Any unauthorized alteration, forgery or falsification of the content or appearance of this document is unlawful and offenders may be prosecuted to the fullest extent of the law. Unless otherwise stated the results shown in this test report refer only to the sample(s) tested.

SGS Taiwan Ltd. | 33, Wu Chuan Rd., New Taipei Industrial Park, New Taipei City, Taiwan / 新北市新北產業園區五權路33號
 台灣檢驗科技股份有限公司 | (886-2) 2299-3039 | (886-2) 2299-3237 | www.sgs.tw

Member of SGS Group

TWB 3320844

1001



SYNTECH CORPORATION
FUSIBLE RESISTORS

File No. :	FRN-02
Version :	B
Page :	21/21
Date :	2014.04.21



測試報告
Test Report

號碼(No.) : CE/2014/41231 日期(Date) : 2014/04/14 頁數(Page) : 9 of 9

欣統股份有限公司 / SYNTECH CORPORATION
 台灣省新北市汐止區新台五路一段79號16樓之3 (遠東世界中心)
 16F-3, NO. 79, FAR EAST WORLD CENTER SEC. 1, HSIN
 TAI WU ROAD, HSI-CHIH DIST., NEW TAIPEI CITY, TAIWAN
 (東莞欣統電子有限公司 / DONG GUAN SYNTECH CORPORATION)
 (廣東省東莞市大朗鎮水口村水常一路13號)
 (NO. 13, SHUICHANG FIRST ROAD, SHUIKOU VILLAGE,
 DALANG TOWN, DONGGUAN, GUANGDONG, CHINA)



* 照片中如有箭頭標示，則表示為實際檢測之樣品/部位。
 (The tested sample / part is marked by an arrow if it's shown on the photo.)

CE/2014/41231

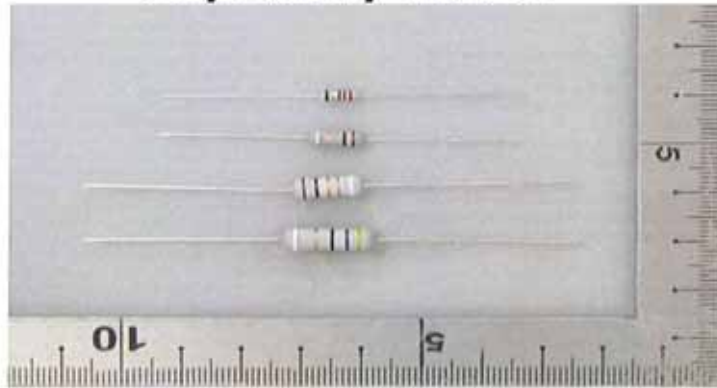

** 報告結尾(End of Report) **

This document is issued by the Company subject to its General Conditions of Service printed overleaf, available on request or accessible at <http://www.sgs.com/en/Terms-and-Conditions.aspx> and, for electronic format documents, subject to Terms and Conditions for Electronic Documents at <http://www.sgs.com/en/Terms-and-Conditions/Edoc/Terms-and-Conditions.aspx>. Attention is drawn to the limitation of liability, indemnification and jurisdiction issues defined therein. Any holder of this document is advised that information contained hereon reflects the Company's findings at the time of its intervention only and within the limits of Client's instructions, if any. The Company's sole responsibility is to its Client and this document does not exonerate parties to a transaction from exercising all their rights and obligations under the transaction documents. This document cannot be reproduced except in full, without prior written approval of the Company. Any unauthorized alteration, forgery or falsification of the content or appearance of this document is unlawful and offenders may be prosecuted to the fullest extent of the law. Unless otherwise stated the results shown in this test report refer only to the sample(s) tested.

SGS Taiwan Ltd.
 台灣檢驗科技股份有限公司

33, Wu Chuan Rd., New Taipei Industrial Park, New Taipei City, Taiwan / 新北市新北產業園區五權路33號
 ☎ (886-2) 2299-3939 ☎ (886-2) 2299-3237 www.sgs.tw

Member of SGS Group

TWB3320845

1001