



MODULAR DESIGN FOR MULTI-OUTPUT SMPS WITH SYNCHRONOUS POST REGULATION

by L. Wuidart

ABSTRACT

This paper proposes a modular way of designing multiple output SMPS. A Synchronous Post Regulator, (SPR), circuit is described in detail. This circuit is able to post-regulate both flyback and forward outputs and has built-in protection features.

An asymmetrical half bridge converter working in flyback mode was made using two independent modular SPR outputs.

A comparison of the resulting operation is made between this modular SPR circuit and an equivalent conventional SMPS with two outputs.

INTRODUCTION

Usually Switch Mode Power Supplies, (SMPS), use a transformer as galvanic insulation between the primary source, which can be the rectified mains or a battery, and the secondary low voltage d.c. outputs.

A particular difficulty that power supply designers often encounter is: how to regulate several output voltages, independently loaded, but having a common duty cycle fixed by the power level switched in the primary.

For this reason a compromise between cost and performance of the solutions available must be made by the designer. These solutions are outlined in figure 1a, which shows the secondary side of a multi-output flyback converter.

APPLICATION NOTE

Figure 1A : Post regulators review in a multi-output flyback:

- L78XX linear (<1A): cost effective but low efficiency.
- Step down converter L497XA (3A-->8A): High precision output voltage with additional LC filter and rectifier.
- Mag. amp. circuit (>8A): High efficiency but no "open load" regulation.

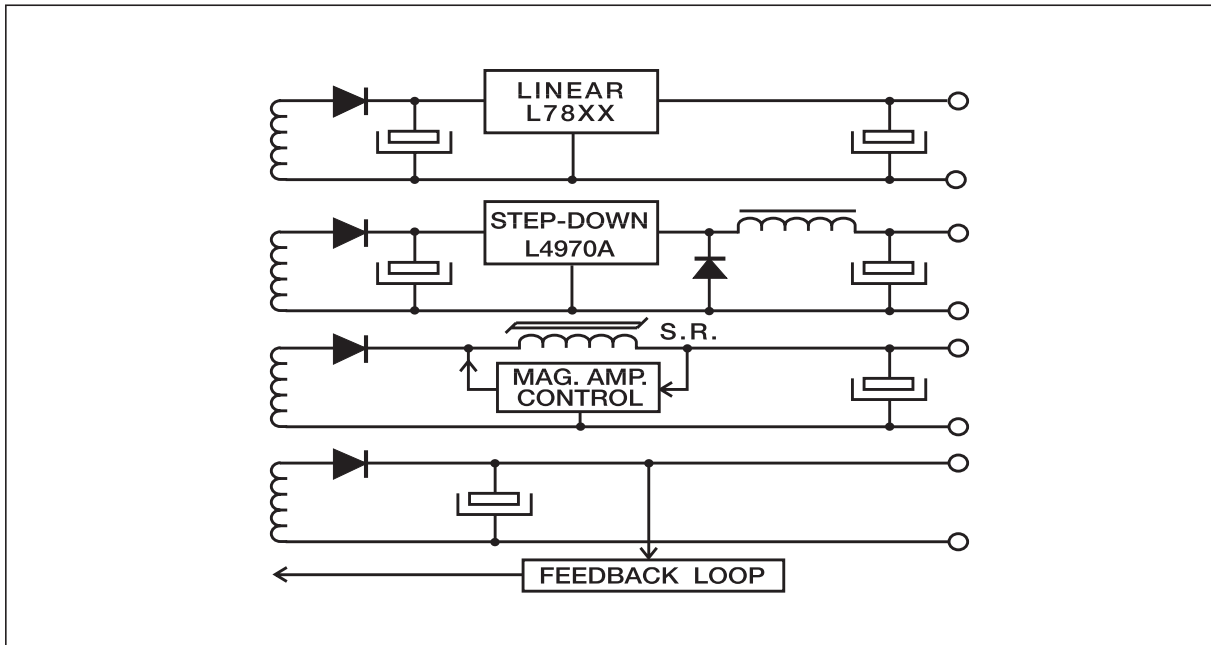

REVIEW OF EXISTING POST REGULATORS

The linear post regulator is probably the most popular solution for low current applications (<1A). But this cost effective approach suffers from high dissipation and poor efficiency.

For the higher current range, >8A, the magnetic amplifier still has a good overall performance. The magnetic amplifier circuit has a high efficiency and the ability to handle high output currents. But the difficulty in implementing effective current limiting and the poor regulation output performance (open load) has often restricted the use of this circuit.

For the medium current range, 3A to 8A, the housing size and especially the cost of a magnetic amplifier core are no longer attractive. In this range of application, high

efficiency step down converters, for example the L4970A family can be used as non-synchronized post regulators. This type of solution provides a high precision output voltage and is well suited to distributed power supply concept [1]. However, this step-down topology always requires additional components, i.e. an LC filter and rectifier.

A synchronous semiconductor switch has many advantages over a comparable saturable reactor, particularly in medium power applications. Indeed, a semiconductor switch gives excellent load regulation performance. Control and protection functions such as over current limiting, short-circuit shutdown, remote on/off, etc. are easily implemented in a semiconductor switch. This type of synchronous post regulator allows the construction of a multi-output SMPS in a completely modular way, see Fig. 1b.

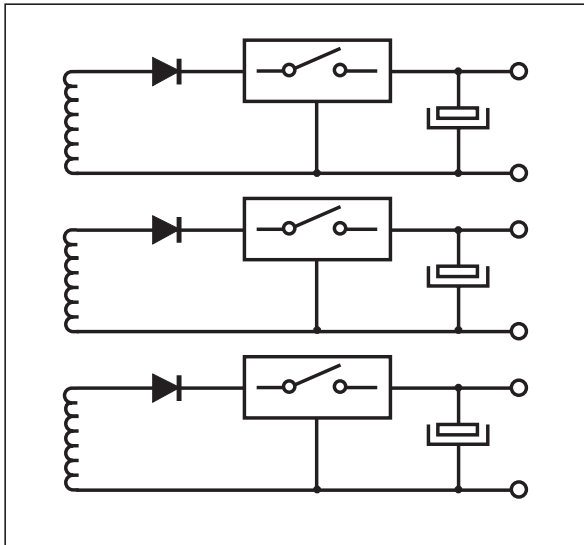

Figure 1b : SPR modular multi-output SMPS design: Each output can be designed as an independent single output channel delivering
 $P_{out} = V_{out} \times I_{out}$

SYNCHRONOUS POST REGULATOR CONTROL PRINCIPLES

The saturable reactor of a magnetic amplifier used in an SMPS output stage (Fig.1a) can be replaced by a driven switch in series with the rectifier. This configuration has given rise to the term Synchronous Post Regulator, SPR. In this configuration a voltage controlled PWM circuit synchronized with the switching frequency controls the turn-on delay of the power switch. The circuit is designed so that zero turn-on delay corresponds to maximum load level.

The basic reason for using delayed turn-on rather than delayed turn-off for controlling the output is because interrupting the flow of current through the secondary parasitic stray inductance would produce over-voltages across the switch (fig.2). This would require a dissipative clamping snubber to protect the SPR against potentially damaging over-voltages.

Delayed turn-on control is well suited to discontinuous mode flyback operation because zero turn-off current avoids recovery losses in the series rectifier.

Figure 2 : SPR control principle : “delayed turn-on rather than delayed turn-off” in order to avoid over-voltages across the switch due to sharp current changes in the parasitic stray inductance.

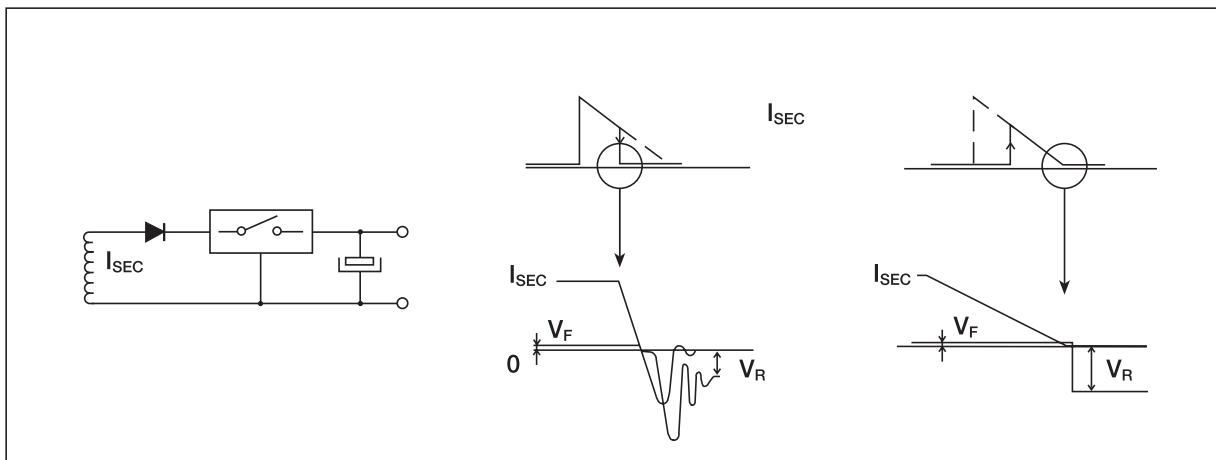

APPLICATION NOTE

CIRCUIT DESCRIPTION

The block diagram in figure 3 shows the principle of operation. The output voltage of

the transformer is pulse width modulated by a power MOSFET switch. The efficiency of the switch will depend on the $R_{DS(on)}$ of the Power MOSFET.

Figure 3: SPR block diagram : A voltage mode PWM synchronized with the switching frequency controls the turn-on delay of the power MOS.

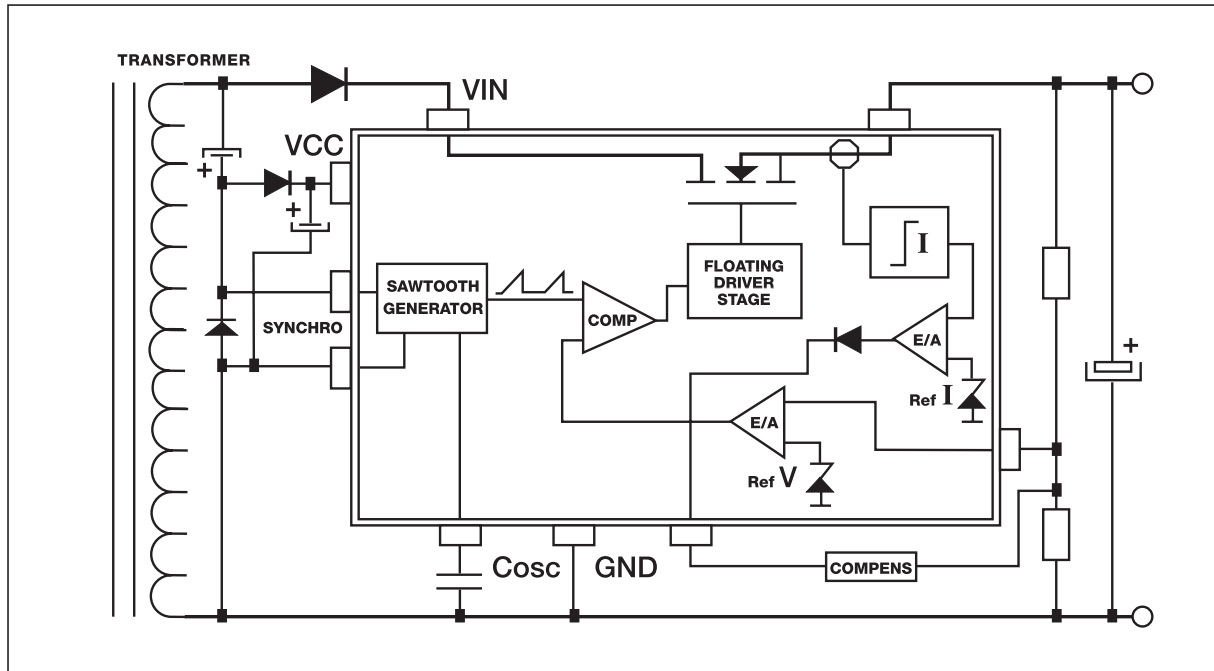

A series rectifier is necessary to avoid reverse conduction through the power MOSFET body diode during primary on-time (reverse mode : see fig.4). The

reverse breakdown voltage rating of this rectifier is the same as for a conventional flyback :

$$(V_{in\ max}/N)+V_{out}$$

Figure 4: Minimum breakdown voltage ratings required for the power MOSFET (mode 1 : direct V_{BR}) and the series rectifier (mode 2 : reverse V_{BR})

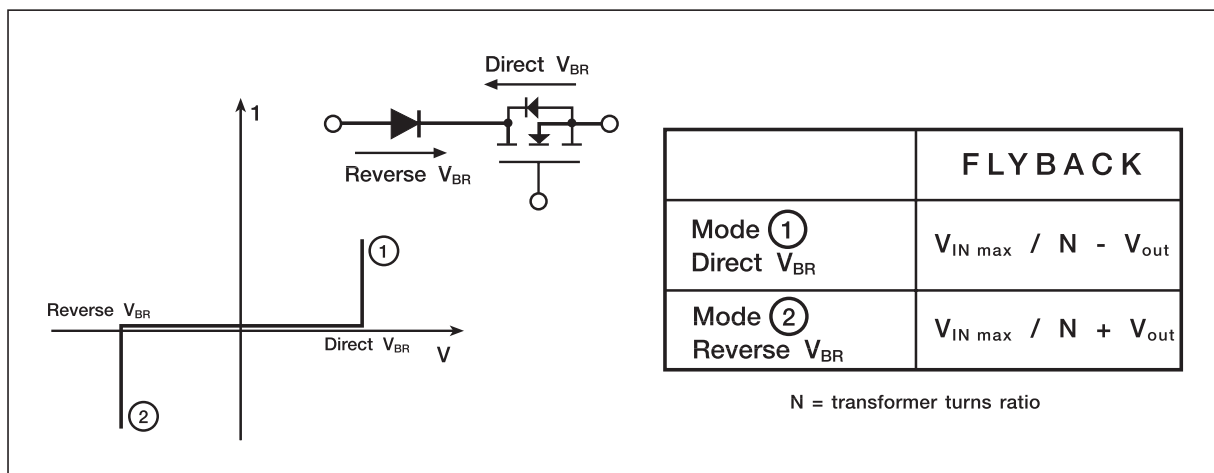

When the SPR is kept off during the flyback direct mode (fig.4), the power MOSFET has to withstand a voltage of $(V_{in_max}/N) - V_{out}$. In practice, a Power MOSFET with a 50V breakdown voltage is enough for both 5V and 15V flyback outputs. Low voltage drops can be achieved by using a power MOSFETs in the isolated ISOWATT218 package such as STH80N05FI ($R_{DSon} = 0.012$ Ohms).

The output voltage error signal controls the delay width before turning the power MOSFET on. The PWM sawtooth ramp is synchronized with the negative edge of the secondary winding voltage (fig.5). This means that 100% of the available flyback current can be transferred to the load without any propagation delay due to the control loop.

Figure 5 : Synchronization of the PWM sawtooth ramp with the negative edge of the secondary winding voltage allows 100% of the flyback energy to be transferred to the load.

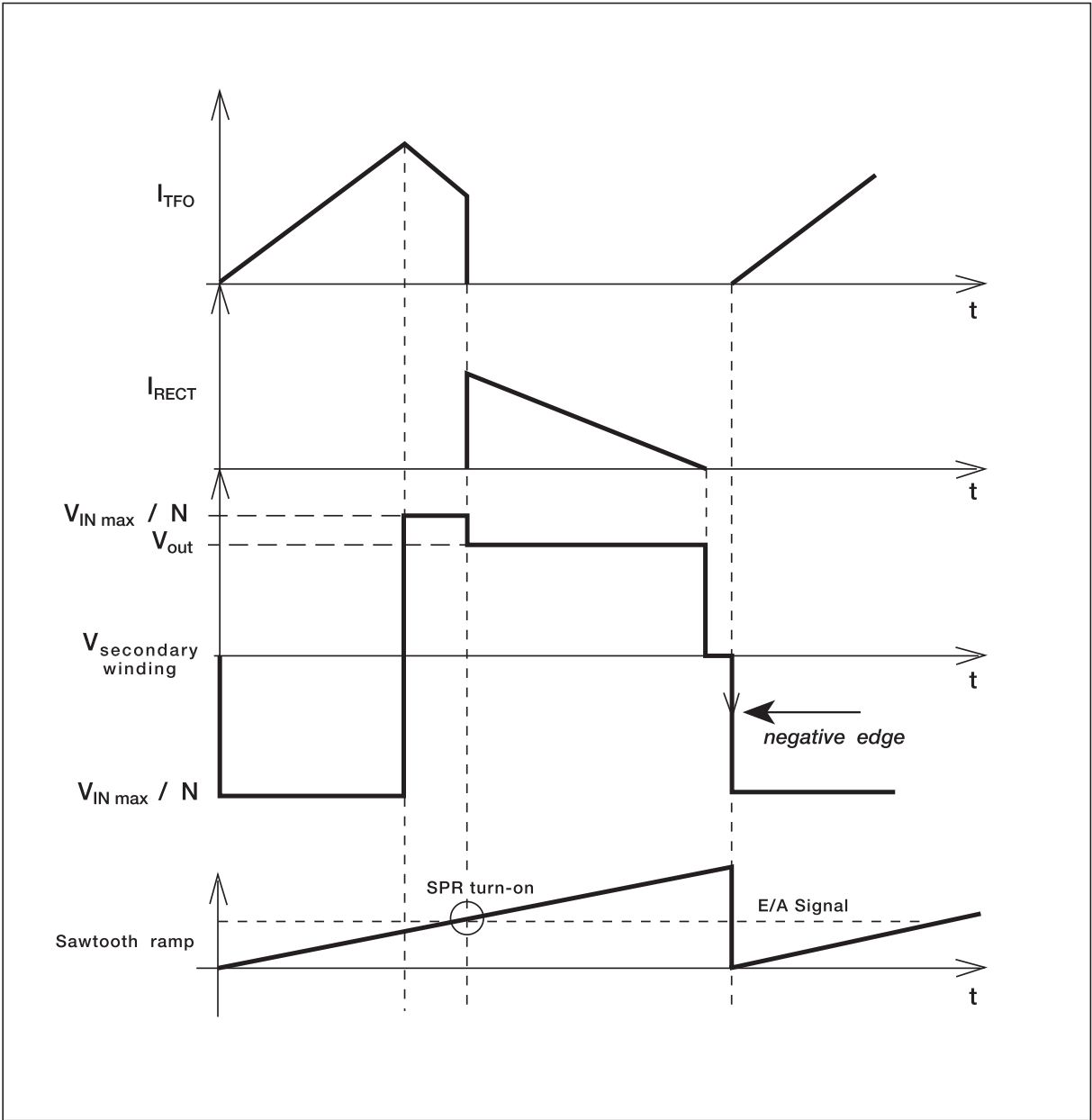

APPLICATION NOTE

As the power MOSFET has to be driven properly in “high side configuration”, the gate driver supply requires a higher voltage than the output. A suitable auxiliary supply can be made without an additional transformer winding. One possibility is to build a voltage doubler with two signal diodes and two small capacitors (fig.6a).

Another method can be to put the flyback rectifier in the negative output rail. Then use a signal diode/capacitor network across the power rectifier which will provide a supply voltage with a maximum output $(V_{out} + V_{in}/N)$ (fig.6b).

Figure 6 : An auxiliary supply, (V_{aux}), higher than the output voltage can be made in flyback mode in two ways:
6a : Voltage doubler circuit
6b: Peak voltage detection circuit across the rectifier put in the negative rail

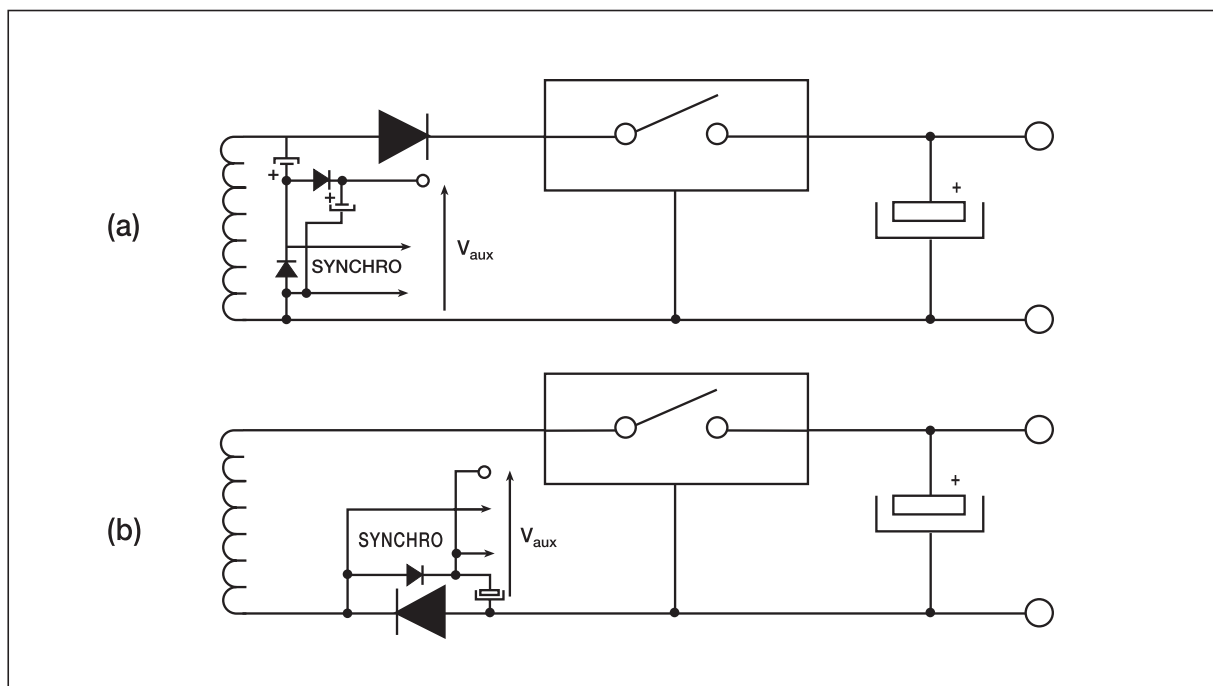

This SPR circuit is also compatible with forward converters (fig.7).

Figure 7: The same Synchronous Post Regulator circuit can be used in forward configuration.

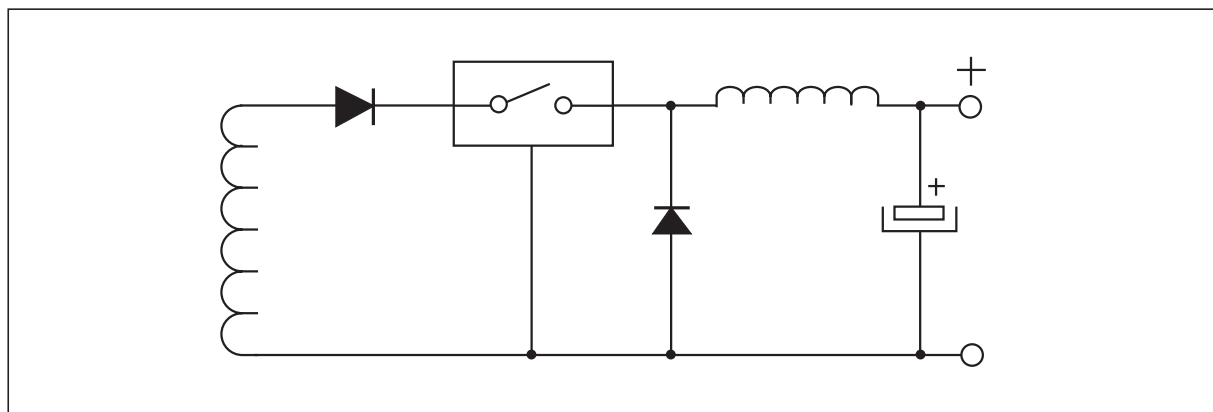

PRACTICAL EXAMPLE

A 60W output asymmetrical half-bridge flyback working in discontinuous mode at 100kHz has been designed to illustrate the

operation of this type of power supply. The converter has two SPR outputs which are completely independent from the primary circuit. Explicitly, there is no feedback loop from secondary to primary side (fig.8).

Figure 8: Asymmetrical half bridge flyback with two Synchronous Post Regulated outputs. There is no feedback loop from secondary to primary.

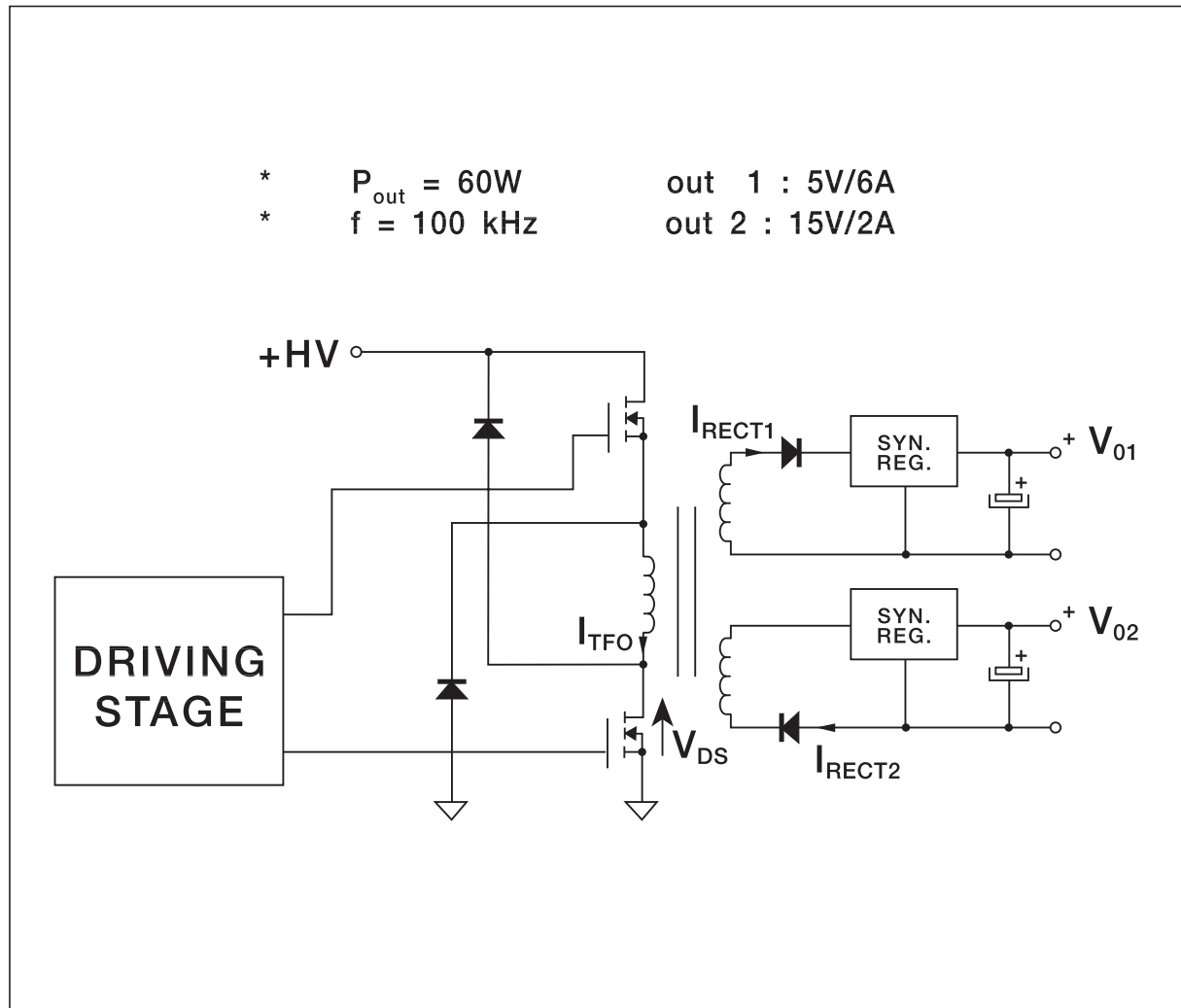

DOUBLE VERSUS SINGLE SWITCH FLYBACK

Earlier applications of some ten years ago avoided the asymmetrical half-bridge configuration for flyback converters because the base drive of the high-side bipolar switch was very complex. The circuit has the advantage of replacing one

1000V switch by two 500V switches. Now it is possible for such an asymmetrical structure to be reconsidered with great interest for 220V AC off-line applications. Indeed, two 500V MOSFETs such as the IRF830FI (isolated ISOWATT220 package) only require a very simple gate driver and, at today's prices, are cost effective (fig.9).

APPLICATION NOTE

Figure 9: Primary side circuit diagram of the asymmetrical half bridge converter.

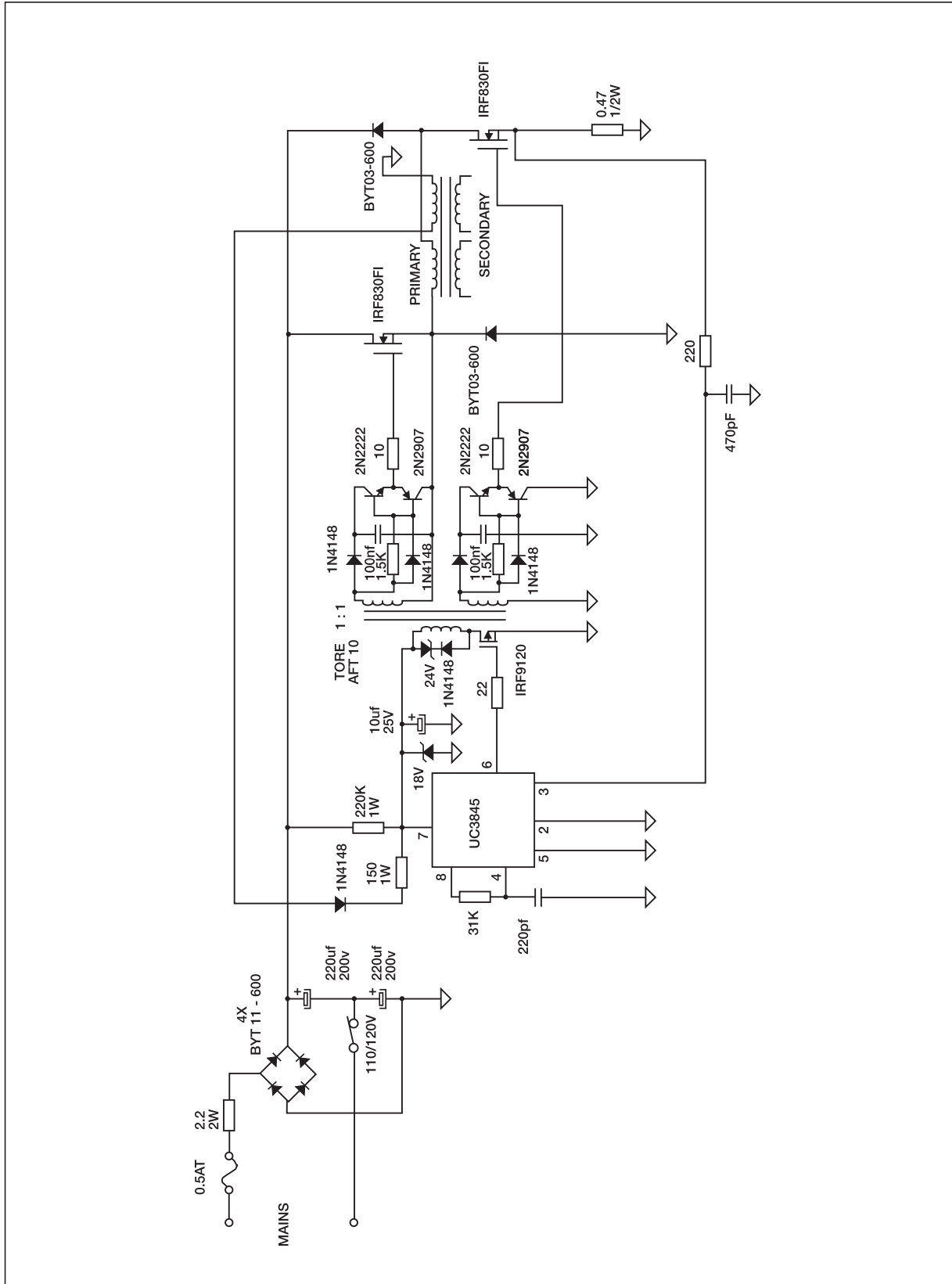

This type of converter structure improves efficiency. Usually, a single switch flyback requires an additional dissipative snubber network to dump the transformer leakage inductance L_{leak} energy (up to 15% of the total output power). In the asymmetrical half-bridge, the energy stored in the

transformer leakage inductance is returned to the reservoir capacitor (fig.10). The two demagnetisation diodes D_1 and D_2 (Axial BYT03-400) provide a simple non-dissipative systematic way to clamp the voltage across the switch to the input line value V_{in} .

Figure10: Single versus double switch flyback:

The energy stored in the transformer leakage inductance, (L_{leak}), of the double switch flyback is returned to reservoir capacitor C_{bulk} avoiding additional dissipative snubber network.

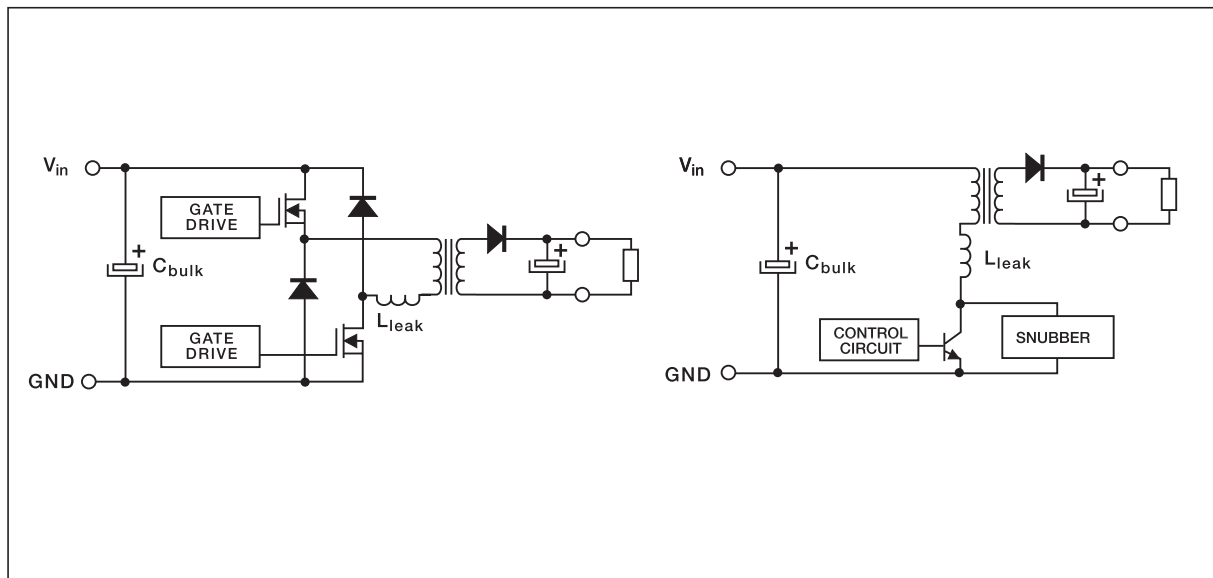

The asymmetrical half-bridge flyback allows the use of SPR without any additional transformer winding and/or components. All the energy stored in the primary inductance which is not transferred to the secondary side is automatically returned to the reservoir capacitor C_{bulk} through the two demagnetisation diodes.

In this way, a completely modular design approach can be used to separate primary and secondary sides:

*On the primary side, (fig.9), the input line voltage is regulated through a simple current mode control, using the low cost UC3845 control IC. For a given line input voltage, current mode control determines

the maximum duty cycle available for all the output channels. The weak point of such a simple system is the poor efficiency at low load level.

*On the secondary side, the SPR only compensates for any load variations since the complete SPR feedback loop is looking for the output voltage variations. So, each SPR output can be designed as an independent self-protected module (fig.1b).

UNDERSTANDING PRACTICAL WAVEFORMS

Practical waveforms of an SPR used in an asymmetrical half-bridge are represented in the oscillogram of Fig.11.

APPLICATION NOTE

Figure 11: Practical waveforms of a Synchronous Post Regulator used in the asymmetrical half-bridge flyback. Parameters are defined in the diagram of Fig. 8. V_G is the gate to source voltage of the SPR power MOSFET.

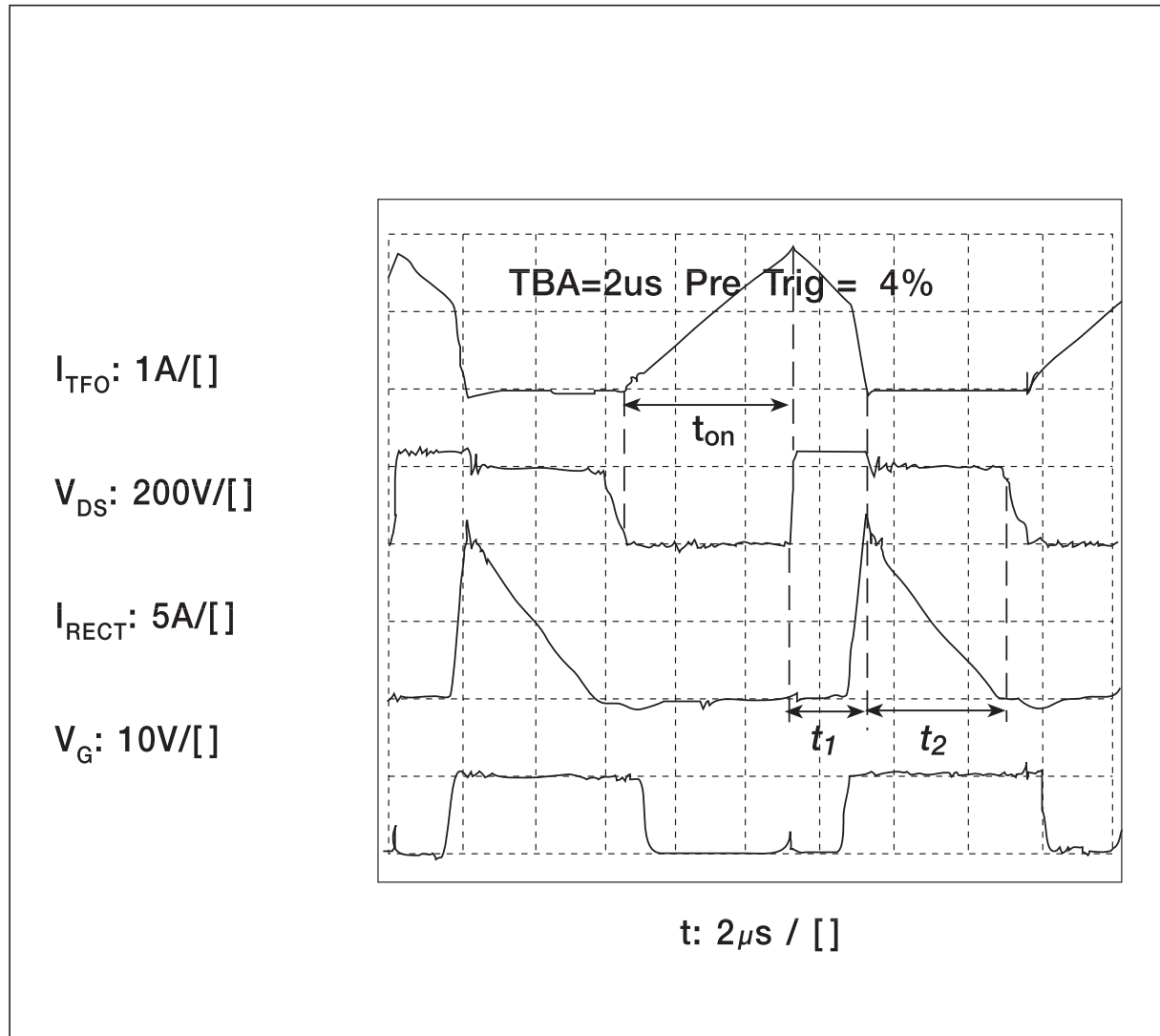

During the on-time, (t_{on}), the current in the transformer primary winding, I_{tfo} , increases with a slope of typically V_{in}/L_p , L_p being the transformer primary winding inductance.

SPR off: interval t_1

When the primary power MOSFETs are turned off, the energy is first returned to reservoir capacitor through demagnetisation diodes, the output being open since the SPR is off. During this period (t_1) the primary current I_{tfo} is

freewheeling with a decreasing slope of $(V_{in}+2V_f)/L_p$ and a voltage of V_{in} is applied across each power MOSFET.

SPR on: interval t_2

As soon as the SPR turns on, energy is transferred from primary to secondary with a corresponding primary current slope of $(V_{in}-NV_0)/L_{leak}$. The rectifier current I_{rect} decreases to zero as in a standard discontinuous flyback circuit.

TWO SPR OUTPUT WAVEFORMS

The following oscillograms (Fig. 12) were taken at 3 different output power levels:

Figure 12: Oscillograms of the 2 Synchronous Post Regulated outputs used in the asymmetrical half-bridge flyback.

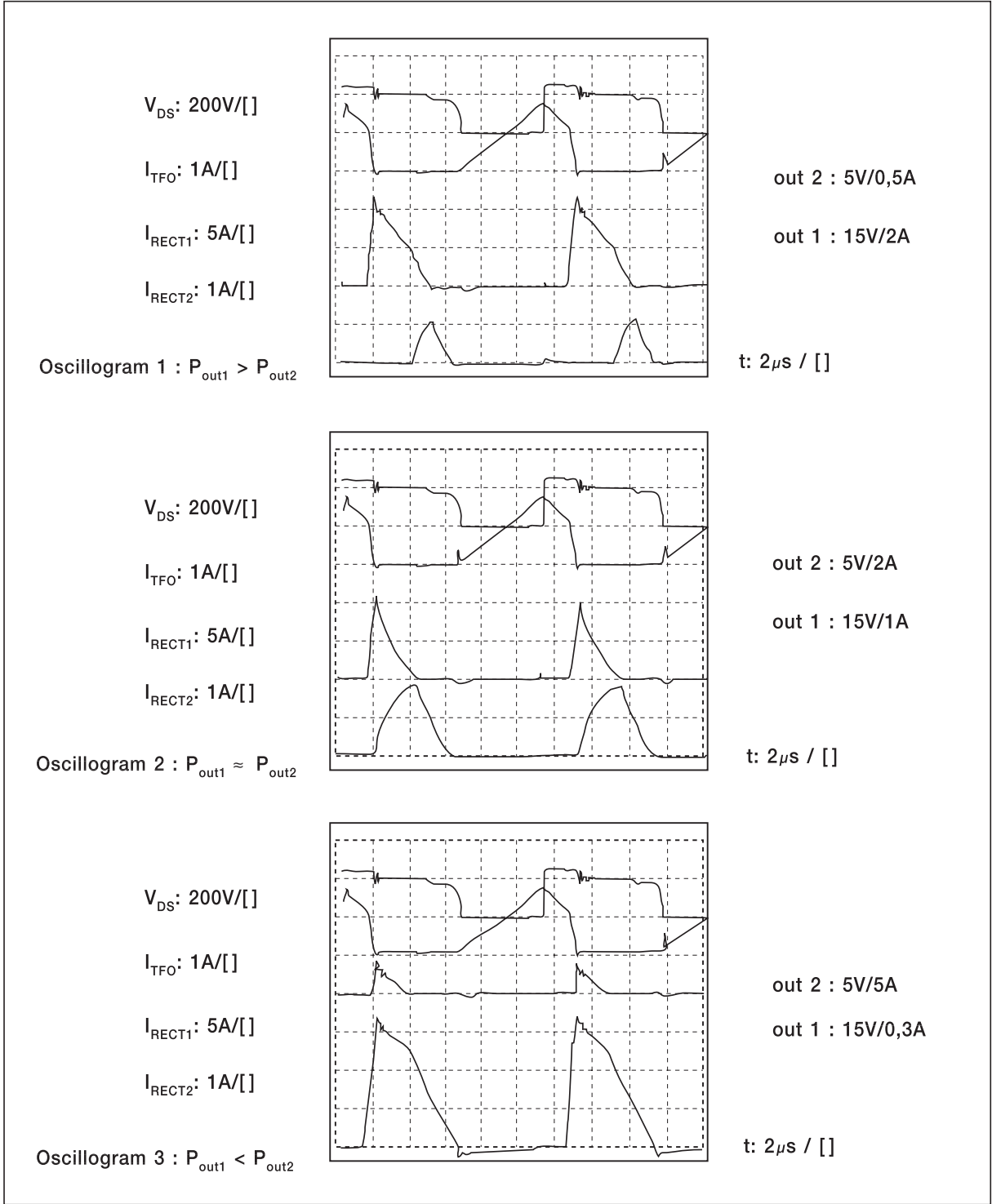

APPLICATION NOTE

Whatever the power balance between the outputs, output 1 is always the first to turn the SPR on. This sequence occurs because of the unbalanced values of each primary reflected output voltage ($N_i V_{oi}$). The primary winding of the transformer has 74 turns. Three turns on the secondary give 5V on output 2, and 6 turns are enough to give 15V on output 1. Output 1, therefore, has a greater reflected voltage than output 2 :

$$N_1 \cdot V_{o1} > N_2 \cdot V_{o2}$$

Serial voltage drops are included in V_{oi} , N_1 and N_2 being the turns ratios of output 1 and output 2, to the primary, respectively.

This ratio of secondary winding turns, which is non-linearly connected to the output voltages, can be realized only by using SPR outputs. This is not possible in conventional flyback circuits.

EFFECTS OF UNBALANCED $N_i V_{oi}$

Assuming that $N_1 V_{o1} > N_2 V_{o2}$ and $(N_1 V_{o1}/N_2 V_{o2}) = C$, then:

1. The lowest reflected output voltage ($N_2 V_{o2}$) has the maximum output power capability.

$$P_{out2\ max} = P_{out1\ max} \times C \text{ with } C > 1$$

2. The highest reflected voltage ($N_1 V_{o1}$) has a degraded load regulation effect.

Those two effects have also been detected in our example. In this case ,

$$(N_1 V_{o1}/N_2 V_{o2}) = 197/160 \approx 1.2$$

The maximum measured output power capability for each secondary channel, the other channel being open loaded:

$$\begin{aligned} P_{out2\ max} &= 60W \text{ (5V output)} \\ \text{and } P_{out1\ max} &= 49W \text{ (15V output)} \end{aligned}$$

With the other output 50% loaded, the load regulation for a 0 --> 100% load variation was measured as:

$$\begin{aligned} \text{output 1: 15V} &\text{ --> } \pm 0.45\% \\ \text{output 2: 5V} &\text{ --> } \pm 0.1\% \end{aligned}$$

SMPS DESIGN CONSEQUENCES

The use of an SPR circuit facilitates SMPS design by avoiding several difficult points commonly met in a typical multi-output flyback.

* Power transformer

- Even if a high frequency transformer gives high volts per turn, the secondary turns adjustment is more flexible than in the conventional flyback. In our example, 3 turns for 5V, and 6 turns for 15V output.

- Tight coupling between secondary windings is not so critical anymore, since cross regulation effects between the different output channels are compensated by SPR circuits.

* Protection

A SPR circuit can perform effective output protection against overload, short-circuit and over-voltage since these functions are decentralized in each channel.

* Standard approval costs

The cost of the expensive UL/VDE approved opto-coupler in conventional secondary to primary feedback loops can be saved by using SPR modular approach. Moreover, any combination of any approved SPR module that complies with safety standards, makes approval procedures more rapid.

CONVENTIONAL VERSUS MODULAR APPROACH

Load and cross regulation performance between a conventional and an SPR modular flyback converter are compared in Fig. 13.

Figure 13: Comparison of load and cross regulation between the SPR modular flyback converter under test and a comparable conventional version.

| $P_{out} = 60W$ at: $5V/6A$ $f = 100kHz$ and $15V/2A$ | | |
|--|--------------------------|---------------------------|
| | CONVENTIONAL | MODULAR |
| LOAD REGULATION 50% load on the other output - Reg. out. (0 -> 100% load) - Unreg. out. (50 -> 100% load) | $\pm 0,2\%$ $\pm 5\%$ | $\pm 0,05\%$ $\pm 2\%$ |
| CROSS REGULATION Influence on the indicated out (50% load) for a load variation from 20% to 100% on any other output - reg. out. - unreg. out. | $\pm 1\%$ $\pm 5\%$ | nil $< \pm 2,5\%$ |

Better load and cross regulation are observed in the unregulated outputs of the modular approach. This is because the

maximum duty cycle in the modular approach is independent of the load.

CONCLUSION

In typical multi-output SMPS, a common design difficulty is to achieve tight regulation in auxiliary outputs, mainly because of leakage inductances between the power transformer windings but also because of the different forward voltage drops of rectifiers.

Also, high frequency transformer design gives high volts per turn, meaning more volts supplied than are actually required.

The proposed SPR circuit can easily compensate for the cross regulation effects and also efficiently protect each output. Furthermore, a secondary to primary feedback loop is not required when using this modular concept.

For medium current range the synchronous post regulator offers many advantages over the other comparable solutions. Decentralized control and protection functions can be easily implemented in an SPR circuit. An interesting application example is the tape video recorder SMPS. Here an SPR circuit can be directly interfaced with a microcontroller,

programming the output voltage for proper motor control. Another diagnostic function could indicate a fault condition, over-temperature, short-circuit etc., to the microcontroller by an external status output signal.

The potential to integrate all those control functions into a monolithic IC, gives the SPR an additional advantage over other circuits. Each output can be effectively considered as an independent self-protected module. This modular design approach can dramatically reduce power supply development time.

REFERENCE

- [1] DATA SHEET L4970A, 10A switching regulator. Industrial and computer peripheral ICs DATA BOOK, 2nd Edition
- [2] R.D. Middlebrook: Topics in multiple - loop regulators and current - mode programming. IEEE: PESC 1985

Information furnished is believed to be accurate and reliable. However, STMicroelectronics assumes no responsibility for the consequences of use of such information nor for any infringement of patents or other rights of third parties which may result from its use. No license is granted by implication or otherwise under any patent or patent rights of STMicroelectronics. Specification mentioned in this publication are subject to change without notice. This publication supersedes and replaces all information previously supplied. STMicroelectronics products are not authorized for use as critical components in life support devices or systems without express written approval of STMicroelectronics.

The ST logo is a trademark of STMicroelectronics

© 1999 STMicroelectronics - Printed in Italy - All Rights Reserved

STMicroelectronics GROUP OF COMPANIES

Australia - Brazil - China - Finland - France - Germany - Hong Kong - India - Italy - Japan - Malaysia - Malta - Morocco - Singapore - Spain - Sweden - Switzerland - United Kingdom - U.S.A.

<http://www.st.com>