

Note: Follow the disassembly procedure in the numerical order given.

3-2. Case (Lower)

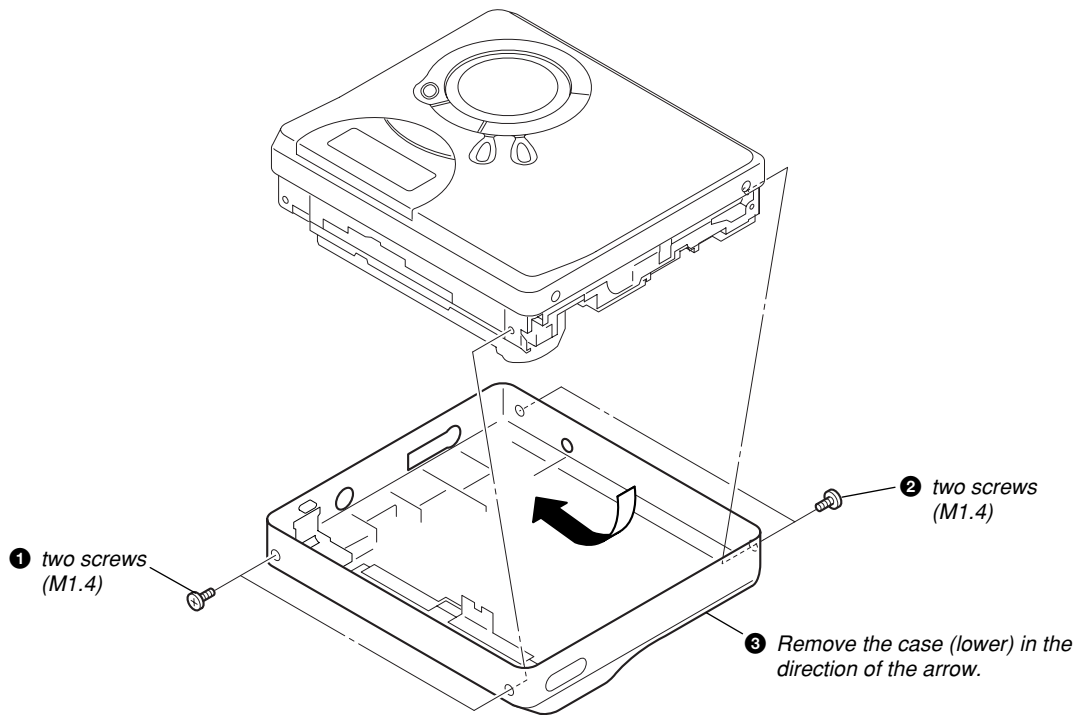

3-3. Upper Panel Section

