

**DISPLAY Elektronik GmbH**

# DATA SHEET

**LCD MODULE**

## **DEM 128064H SYH-PY**

*Product Specification*

*Version: 2*

**25/Mar/2009**

# GENERAL SPECIFICATION

---

MODULE NO. :

# DEM 128064H SYH-PY

CUSTOMER P/N

Version No.	Change Description	Date
0	ORIGINAL VERSION	11.07.2006
1	CHANGE BLOCK DIAGRAM	18.08.2006
2	CHANGE IC	25.03.2009

PREPARED BY: XYP

DATE: 25.03.2009

APPROVED BY: MH

DATE: 25.03.2009

**CONTENTS**

1. FUNCTIONS & FEATURES.....2

2. MODULE ARTWORK.....2

3. EXTERNAL DIMENSIONS .....3

4. BLOCK DIAGRAM.....3

5. PIN ASSIGNMENT .....4

6. POWER SUPPLY.....4

7. PCB DRAWING .....5

8. BACKLIGHT ELECTRICAL/OPTICAL SPECIFICATIONS.....7

9. ABSOLUTE MAXIMUM RATINGS .....7

10. ELECTRICAL CHARACTERISTICS .....8

11. PRECAUTION FOR USING LCM .....11

**1. FUNCTIONS & FEATURES**

MODULE NAME	LCD Type
DEM 128064H SYH-PY	STN Yellow-Green Transflective Positive Mode

- Display Format : 128 x 64 Dots
- Glass Thickness : 1.1mm
- Viewing Direction : 6 o'clock
- Driving Scheme : 1/64 Duty, 1/9 Bias
- Power Supply for logic : 5.0 Volt (typ.)
- V<sub>LCD</sub> : 12.6 Volt (typ.)
- Operating Temperature : -20°C to +70°C
- Storage Temperature : -25°C to +75°C
- Integrated LCD-Controller : T6963C (Toshiba)
- DC/DC-Converter : NJU7670M (or equivalent) on Board

**2. MODULE ARTWORK**

- Module Size : 78.00 x 70.00 x 12.60 mm
- Viewing Area : 62.00 x 44.00 mm
- Active Area : 56.27 x 38.35 mm
- Dot Pitch : 0.44 x 0.60 mm
- Dot Size : 0.39 x 0.55 mm
- Dot Gap : 0.05 mm

3. EXTERNAL DIMENSIONS

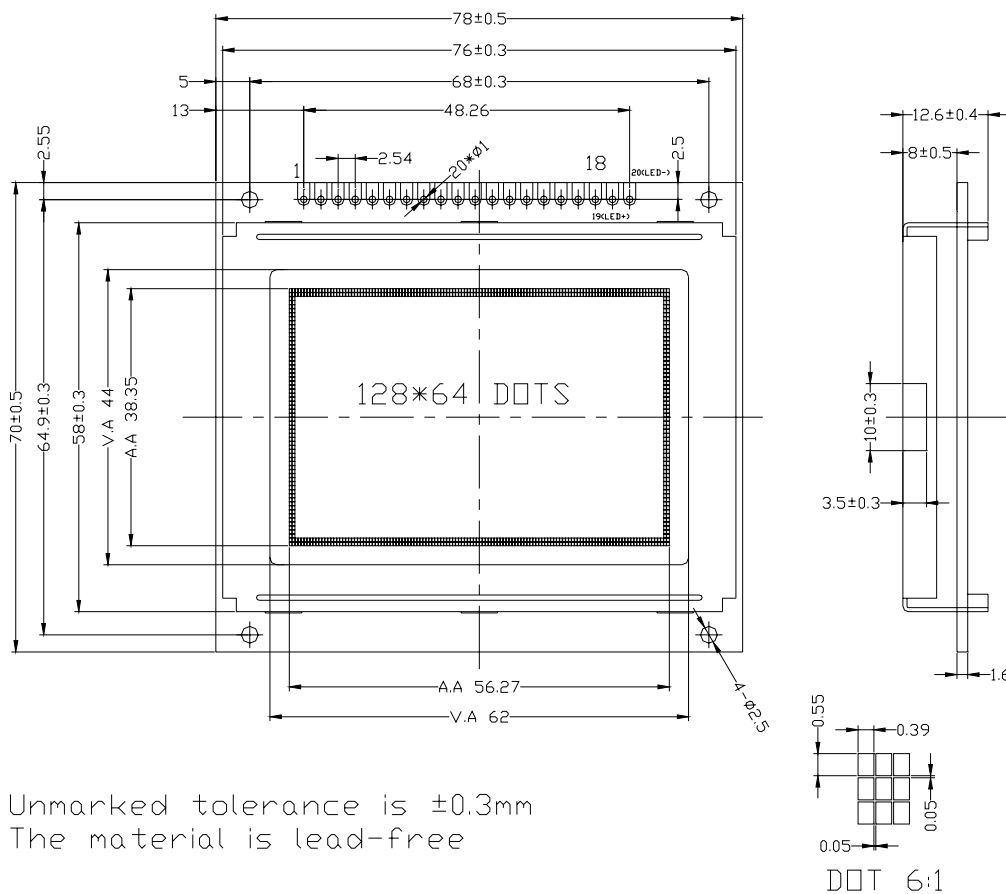

4. BLOCK DIAGRAM

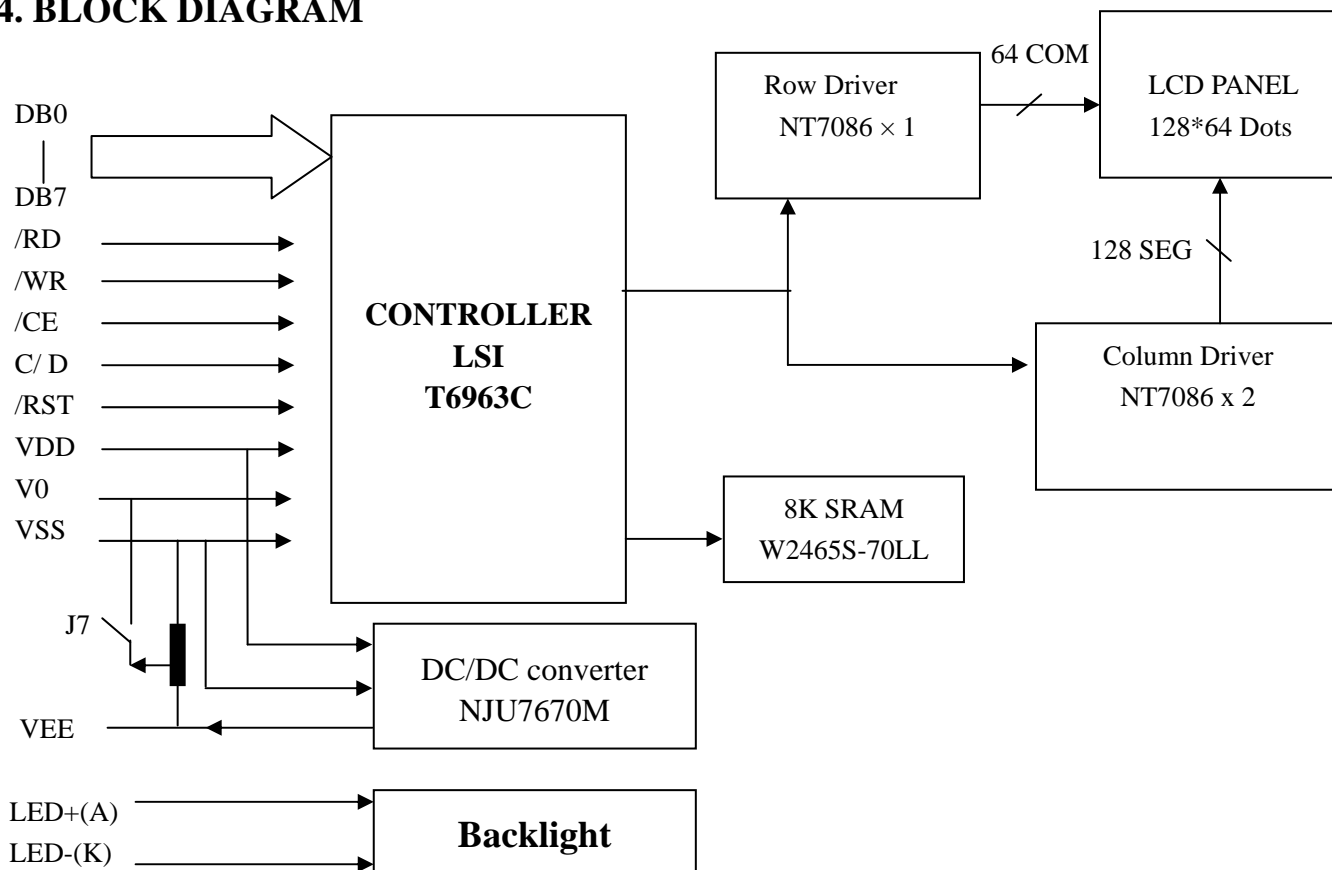

**5. PIN ASSIGNMENT**

NO.	Symbol	Function
1	VEE	Power supply output for LCD
2	VSS	Ground (0V)
3	VDD	Power Supply (+5V)
4	V0	Power Supply for LCD Drive
5	/WR	Data write. Write data to controller T6963C when “L”
6	/RD	Data read. Read data from controller T6963C when “L”
7	/CE	Chip enable of controller when “L”
8	C/ D	Command/Data read/write. “H” for command read/write and “L” for data read/write
9	/RST	Controller reset when “L”
10	DB0	Data input/output(LSB)
11	DB1	Data input/output
12	DB2	Data input/output
13	DB3	Data input/output
14	DB4	Data input/output
15	DB5	Data input/output
16	DB6	Data input/output
17	DB7	Data input/output(MSB)
18	FS	Font select. “H” for 6x8 font & “L” for 8x8 font
19	LED+(A)	Anode of LED backlight
20	LED-(K)	Cathode of LED backlight

**6. POWER SUPPLY**

➤ **Mode(Internal contrast regulation)-J7 is close**

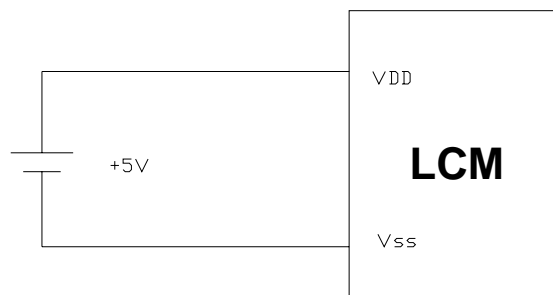

➤ **Mode(external contrast regulation)-J7 is open**

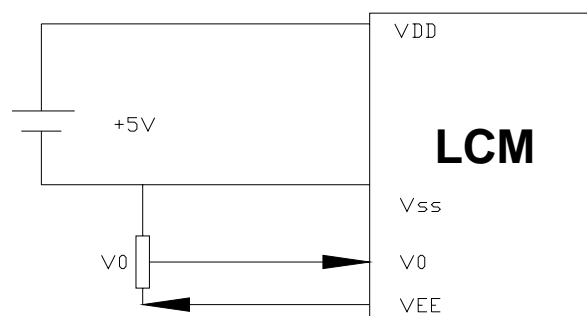

7. PCB DRAWING

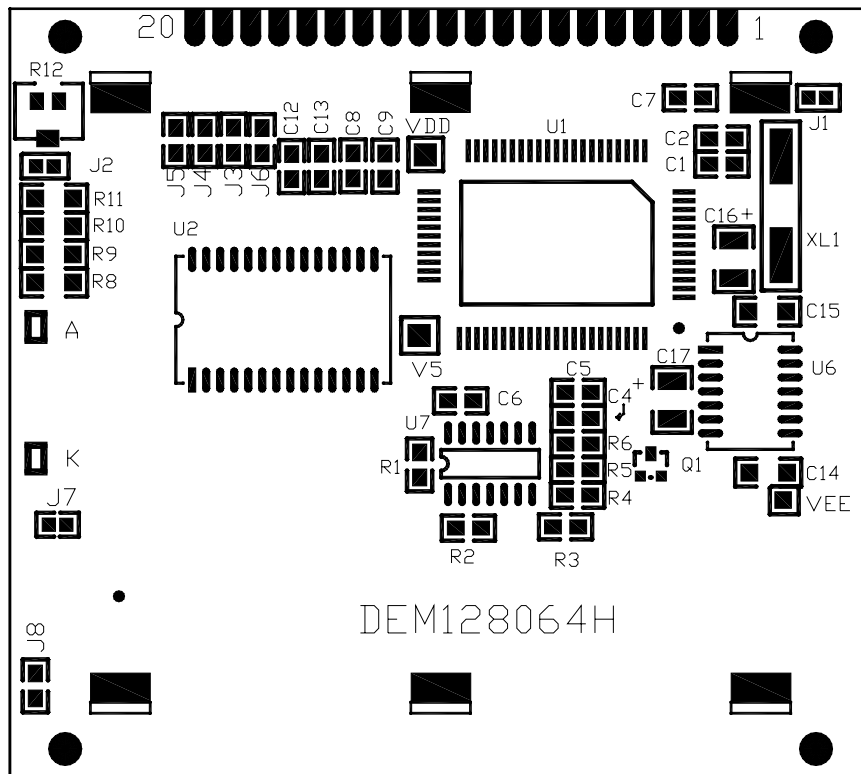

7.1 PCB DESCRIPTION:

7-1-1.The polarity of the pin 19 and the pin 20:

J3,J5	J6, J4	LED Polarity	
		19 Pin	20 Pin
Each closed	Each open	Anode	Cathode
Each open	Each closed	Cathode	Anode

Note: In application module, J3=J5 =closed, J4=J6=open.

7-1-2. The J1 is metal-bezel GND to module GND.

Note: In application module, J1=closed.

7-1-3.The LED resistor should be bridged when J2 is closed.

Note: In application module, J2=open

7-1-4.The module use internal contrast regulation when J7 is closed.

Note: In application module, J7 is open, but potentiometer is calibrated by the factory.

7-1-5. The J8 is mounting holes GND to module GND.

Note: In application module, J8= closed.

7-1-6.The R8 and the R9, R10, R11 are the LED resistor.

Note: In application module, R8=47 Ohm, R9=33 Ohm, R10=R11=Not used.

**7.2 Example application**

7-2-1. The LED resistor should be bridged as following.

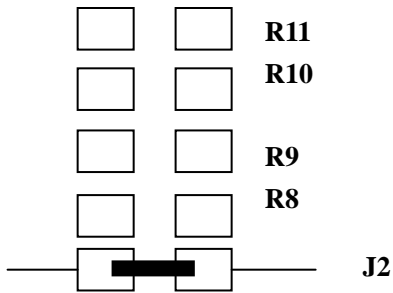

7-2-2. The 19 pin is the anode and the 20 pin is the cathode as following.

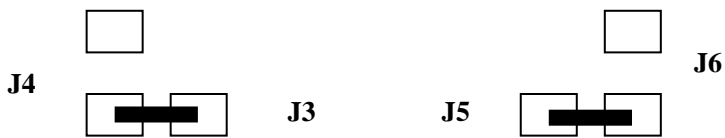

7-2-3. The metal-bezel is on ground as following.

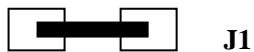

7-2-4. The module use internal contrast regulation as following.



7-2-5. The mounting holes is on ground as following.





**8. BACKLIGHT ELECTRICAL/OPTICAL SPECIFICATIONS**

ELECTRICAL–OPTICAL CHARACTERISTICS

Item	Symbol	min.	typ.	max.	Unit	Condition
Forward Voltage	V <sub>f</sub>	3.7	4.0	4.3	V	I <sub>f</sub> = 50 mA
Reverse Current	I <sub>r</sub>		35		μA	V <sub>r</sub> = 0.8 V
Peak wave length	λ <sub>P</sub>	569	572	575	nm	I <sub>f</sub> = 50 mA
Spectral Line Half width	Δλ				nm	I <sub>f</sub> = 50 mA
Luminance	L <sub>v</sub>	23	33		cd/m <sup>2</sup>	I <sub>f</sub> = 50 mA

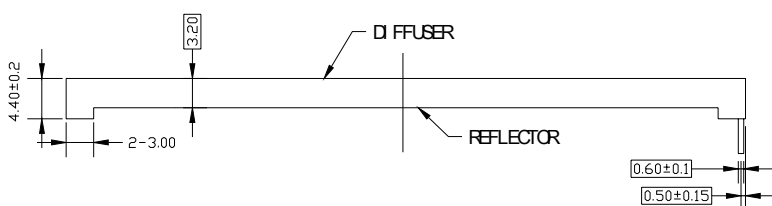
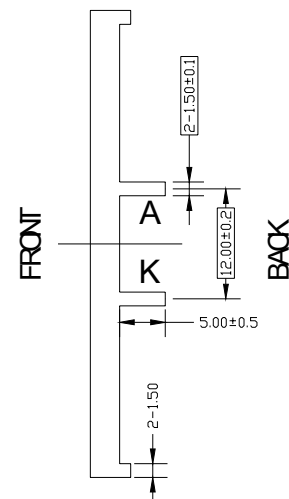
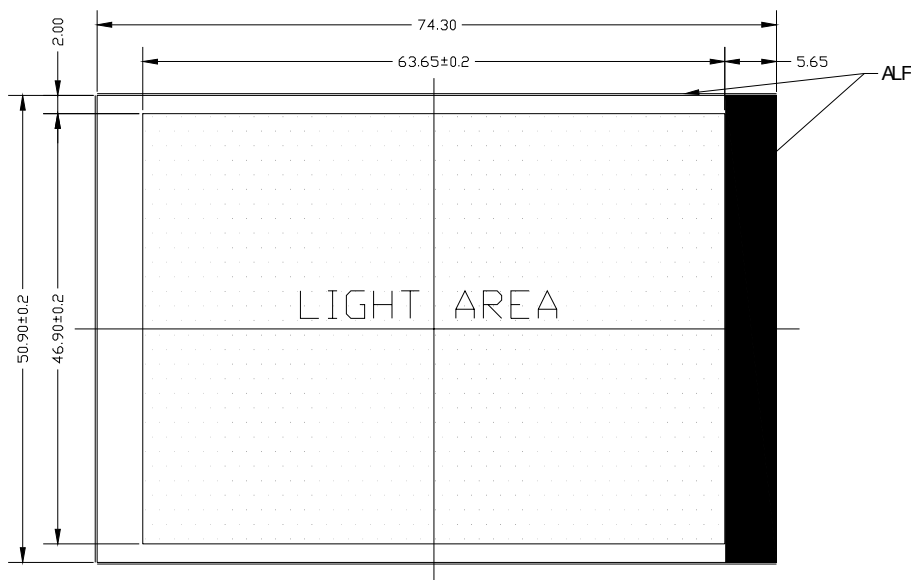

CIRCUIT DIAGRAM (LED 2x5=10 dies)

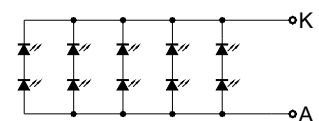

REMARKS:  
 1, UNMARKED TOLERANCE IS ±0.3,  
 2, THE MATERIAL IS LEAD-FREE,  
 3, THE COLOR IS YELLOW-GREEN.

**9. ABSOLUTE MAXIMUM RATINGS**

Parameter	Symbol	Rating	Unit
Supply Voltage (Logic)	V <sub>DD</sub>	-0.3 to 7.0	V
Input voltage	V <sub>IN</sub>	-0.3 to V <sub>DD</sub> +0.3	V
Operating Temperature	T <sub>opr</sub>	-20 to +70	°C
Storage Temperature	T <sub>stg</sub>	-25 to +75	°C

**10. ELECTRICAL CHARACTERISTICS**

**10.1. DC Characteristics**

Parameter	Symbol	Conditions	Min.	Typ.	Max.	Units
Supply Voltage	$V_{DD}-V_{SS}$	-	4.5	5.0	5.5	V
Charge pump output	$V_{LCD}$		12.3	12.6	12.9	V
Current Consumption	$I_{DD}$			t.b.d.		

**10.2. AC Characteristics**

**Read mode**

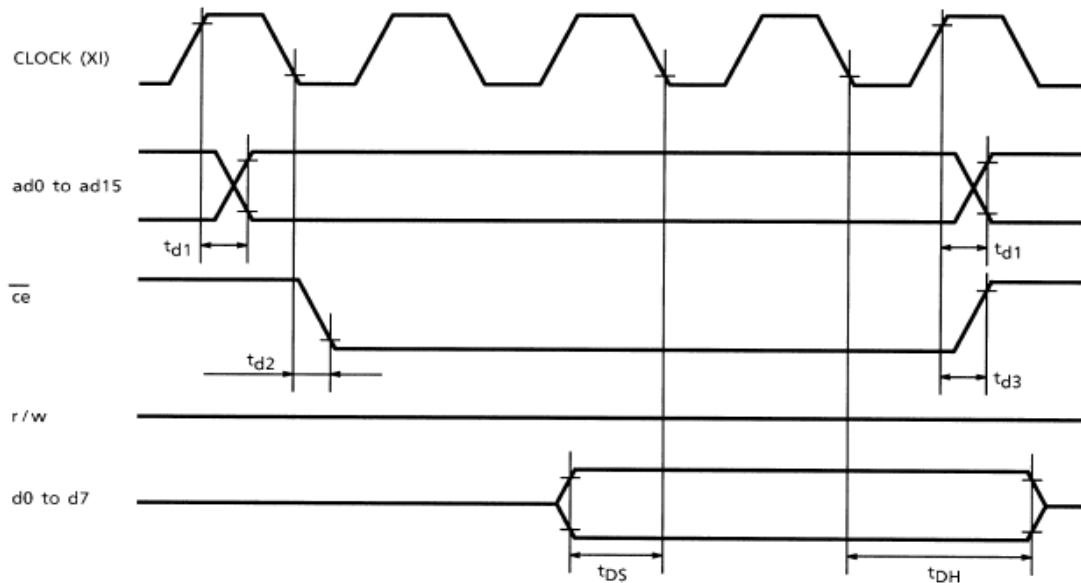

**Write mode**

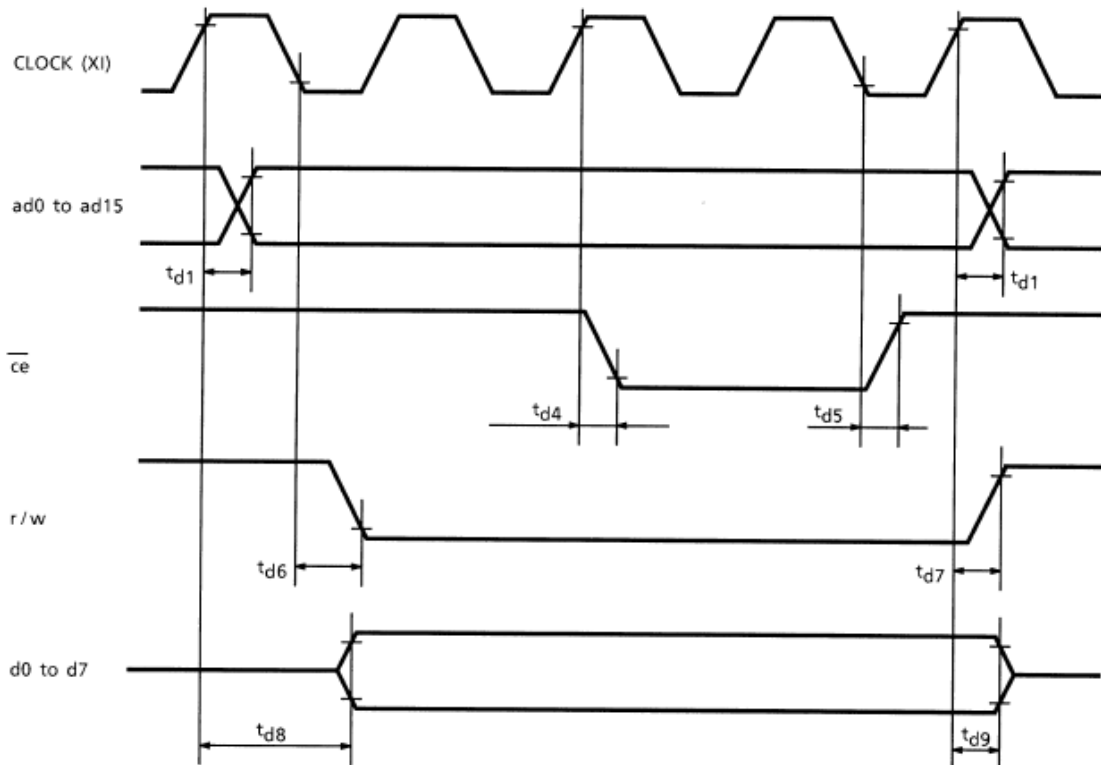

Item	Symbol	Test Conditions	Min	Max	Unit
Address Delay Time	$t_{d1}$	—	—	250	ns
$\overline{ce}$ Fall Delay Time (Read)	$t_{d2}$	—	—	180	ns
$\overline{ce}$ Rise Delay Time (Read)	$t_{d3}$	—	—	180	ns
Data Set-up Time	$t_{DS}$	—	0	—	ns
Data Hold Time	$t_{DH}$	—	30	—	ns
$\overline{ce}$ Fall Delay Time (Write)	$t_{d4}$	—	—	200	ns
$\overline{ce}$ Rise Delay Time (Write)	$t_{d5}$	—	—	200	ns
r / w Fall Delay Time	$t_{d6}$	—	—	180	ns
r / w Rise Delay Time	$t_{d7}$	—	—	180	ns
Data Stable Time	$t_{d8}$	—	—	450	ns
Data Hold Time	$t_{d9}$	—	—	200	ns

**10.3. Power Supply ON/OFF Sequence**

- ON Sequence

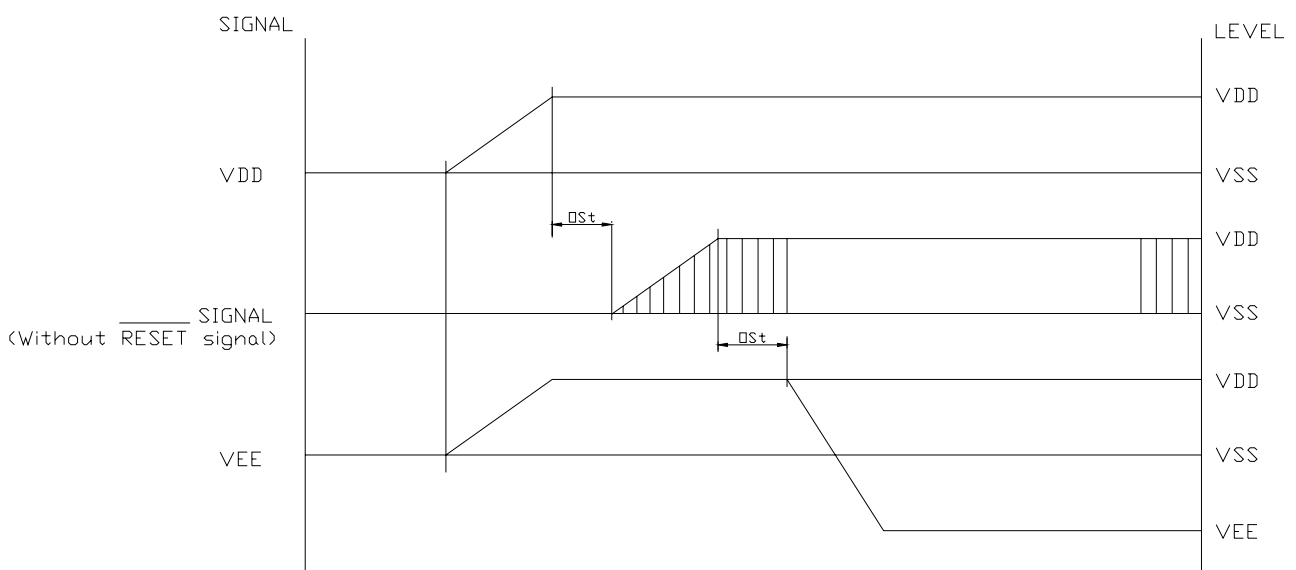

● OFF Sequence

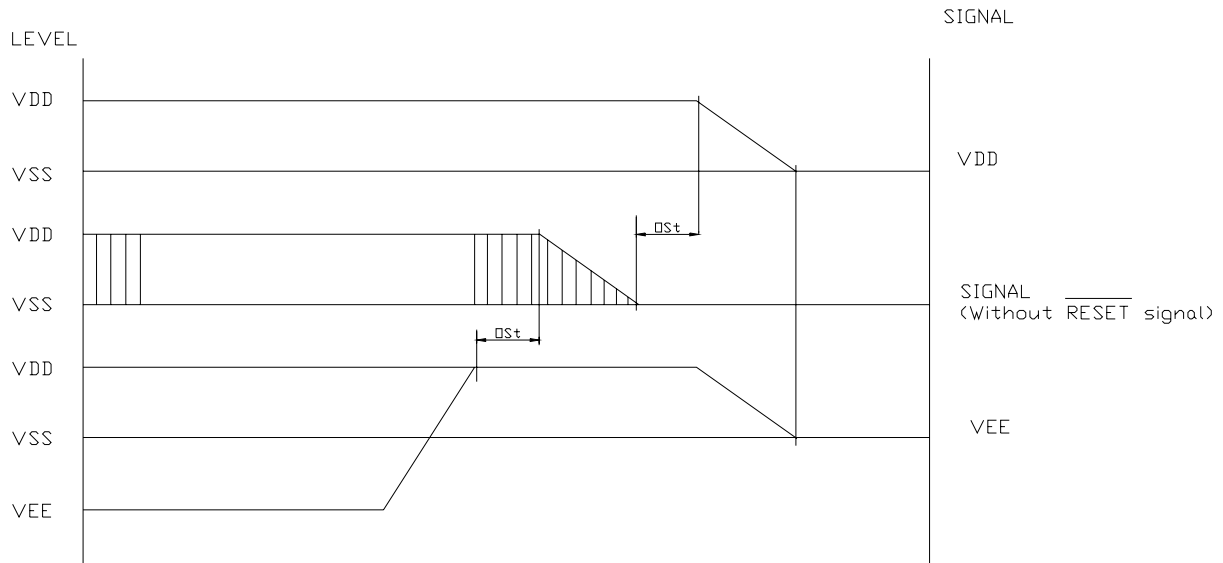

● Reset Sequence

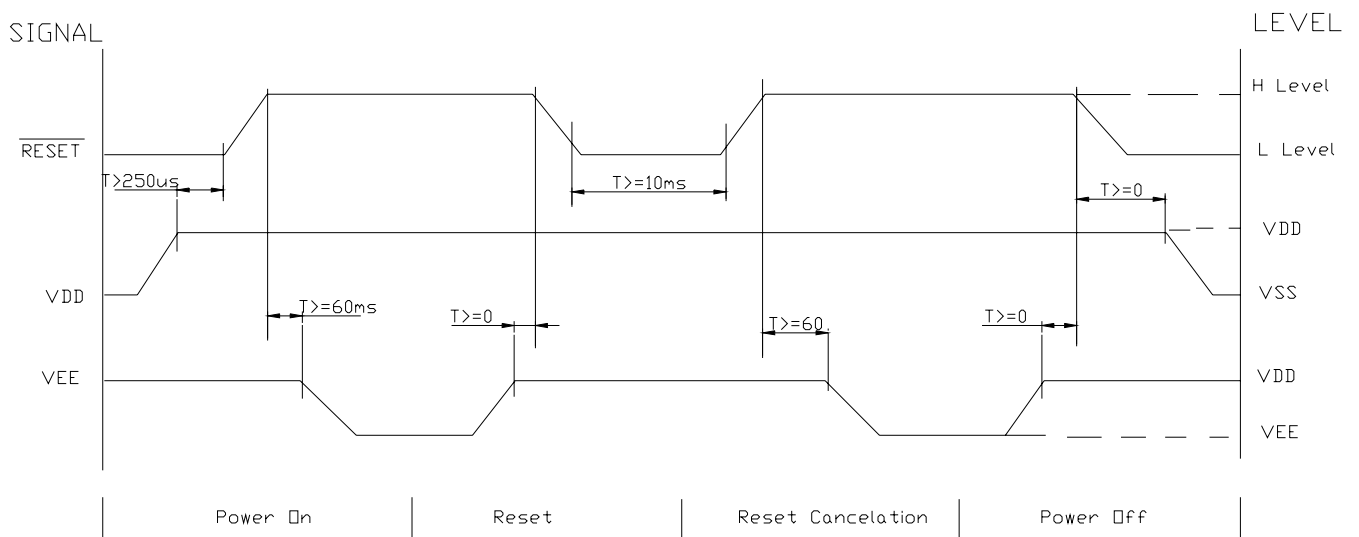

Please maintain the above sequence when turning on and off the power supply of the module.

If VEE is supplied to the module while internal altimeter signal for LCD driving (M) is unstable or RESET is active, DC component will be supplied to the LCD panel. This may cause damage to the LCD module.

## **11. PRECAUTION FOR USING LCM**

### **11.1 LIQUID CRYSTAL DISPLAY (LCD)**

LCD is made up of glass, organic sealant, organic fluid, and polymer based polarizer. The following precautions should be taken when handling,

- (1). Keep the temperature within range of use and storage. Excessive temperature and humidity could cause polarization degradation, polarizer peel off or bubble.
- (2). Do not contact the exposed polarizer with anything harder than an HB pencil lead. To clean dust off the display surface, wipe gently with cotton, chamois or other soft material soaked in petroleum benzene.
- (3). Wipe off saliva or water drops immediately. Contact with water over a long period of time may cause polarizer deformation or color fading, while an active LCD with water condensation on its surface will cause corrosion of ITO electrodes.
- (4). Glass can be easily chipped or cracked from rough handling, especially at corners and edges.
- (5). Do not drive LCD with DC voltage.

### **11.2. Liquid Crystal Display modules**

#### **11.2.1 Mechanical considerations**

LCM are assembled and adjusted with a high degree of precision. Avoid excessive shocks and do not make any alterations or modifications. The following should be noted.

- (1). Do not tamper in any way with the tabs on the metal frame
- (2). Do not modify the PCB by drilling extra holes, changing its outline, moving its components or modifying its pattern.
- (3). Do not touch the Eastover connector, especially insert an backlight panel (for example, EL).
- (4). When mounting a LCM make sure that the PCB is not under any stress such as bending or twisting. Eastover contacts are very delicate and missing pixels could result from slight dislocation of any of the elements.
- (5). Avoid pressing on the metal bezel, otherwise the Eastover connector could be deformed and lose contact, resulting in missing pixels.

#### **11.2.2. Static Electricity**

LCM contains CMOS LSI's and the same precaution for such devices should apply, namely

- (1). The operator should be grounded whenever he/she comes into contact with the module. Never touch any of the conductive parts such as the LSI pads, the copper leads on the PCB and the interface terminals with any parts of the human body.
- (2). The modules should be kept in antistatic bags or other containers resistant to static for storage.
- (3). Only properly grounded soldering irons should be used.
- (4). If an electric screwdriver is used, it should be well grounded and shielded from commentator sparks.
- (5). The normal static prevention measures should be observed for work clothes and working benches; for the latter conductive (rubber) mat is recommended.
- (6). Since dry air is inductive to static, a relative humidity of 50-60% is recommended.

#### **11.2.3. Soldering**

- (1). Solder only to the I/O terminals.
- (2). use only soldering irons with proper grounding and no leakage.
- (3). Soldering temperature:  $280^{\circ}\text{C} \pm 10^{\circ}\text{C}$
- (4). Soldering time: 3 to sec.
- (5). Use eutectic solder with resin flux fill.
- (6). If flux is used, the LCD surface should be covered to avoid flux spatters. Flux residue should be removed afterwards.

**11.2.4 Operation**

- (1). The viewing angle can be adjusted by varying the LCD driving voltage V0.
- (2). Driving voltage should be kept within specified range; excess voltage shortens display life.
- (3). Response time increases with decrease in temperature.
- (4). Display may turn black or dark blue at temperatures above its operational range; this is (however not pressing on the viewing area) may cause the segments to appear “fractured”.
- (5). Mechanical disturbance during operation (such as pressing on the viewing area) may cause the segments to appear “fractured”.

**11.2.5 Storage**

If any fluid leaks out of a damaged glass cell, wash off any human part that comes into contact with soap and water. Never swallow the fluid. The toxicity is extremely low but caution should be exercised at all the time.

**11.2.6 Limited Warranty**

Unless otherwise agreed between DISPLAY and customer, DISPLAY will replace or repair any of its LCD and LCM which is found to be defective electrically and visually when inspected in accordance with DISPLAY acceptance standards, for a period on one year from date of shipment. Confirmation of such date shall be based on freight documents. The warranty liability of DISPLAY is limited to repair and/or replacement on the terms set forth above. DISPLAY will not responsible for any subsequent or consequential events.