

DT-670-SD Features

- Best accuracy across the widest useful temperature range – 1.4 K to 500 K – of any silicon diode in the industry
- Tightest tolerances for applications from 30 K to 500 K of any silicon diode to date
- Rugged, reliable Lake Shore SD package designed to withstand repeated thermal cycling and minimize sensor self-heating
- Conformance to standard Curve DT-670 temperature response curve
- Variety of packaging options

DT-670E-BR Features

- Temperature range: 1.4 K – 500 K
- Bare die sensors with the smallest size and fastest thermal response time of any silicon diode on the market today
- Non-magnetic sensor

Diode Thermometry

Diode thermometry is based on the temperature dependence of the forward voltage drop in a p-n junction biased at a constant current, typically 10 μ A. Because the voltage signal is relatively large, between 0.1 V and 6 V, diodes are easy to use and instrumentation is straightforward.

DT-670 Silicon Diodes

DT-670 Series Silicon Diodes offer better accuracy over a wider temperature range than any previously marketed silicon diodes. Conforming to the Curve DT-670 standard voltage versus temperature response curve, sensors within the DT-670 series are interchangeable, and for many applications do not require individual calibration. DT-670 sensors in the SD package are available in four tolerance bands – three for general cryogenic use across the 1.4 K to 500 K temperature range, and one that offers superior accuracy for applications from 30 K to room temperature. DT-670 sensors also come in a seventh tolerance band, Band E, which are available only as bare die. For applications requiring greater accuracy, DT-670-SD diodes are available with calibration across the full 1.4 K to 500 K temperature range.

The bare die sensor, the DT-670E, provides the smallest physical size and fastest thermal response time of any silicon diode on the market today. This is an important advantage for applications where size and thermal response time are critical, including focal plane arrays and high temperature superconducting filters for cellular communication.

PACKAGING OPTIONS BO, BR, CO, CU, CY, ET, LR, MT

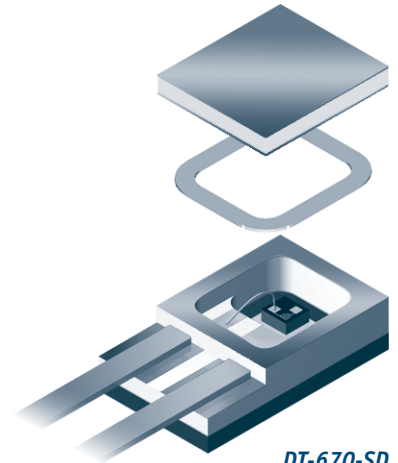

DT-670-SD

The Lake Shore SD Package – The Most Rugged, Versatile Package in the Industry

The SD package, with direct sensor-to-sapphire base mounting, hermetic seal, and brazed Kovar leads, provides the industry's most rugged, versatile sensors with the best sample to chip connection. Designed so heat coming down the leads bypasses the chip, it can survive several thousand hours at 500 K (depending on model) and is compatible with most ultra high vacuum applications. It can be indium soldered to samples without shift in sensor calibration. If desired, the SD package is also available without Kovar leads.

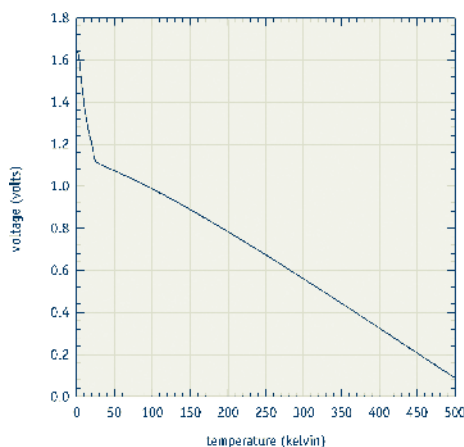
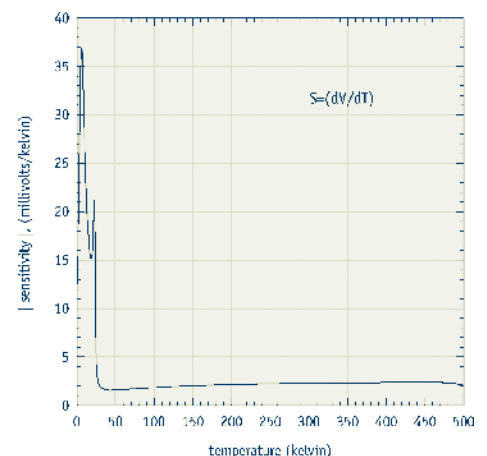
Typical DT-670 Diode Voltage Values**Typical DT-670 Diode Sensitivity Values**

Specifications

Standard curve Curve DT-670 – see next page

Recommended excitation 10 μ A \pm 0.1%

Max reverse voltage 40 V

Max current before damage 1 mA continuous or 100 mA pulsed

Dissipation at recommended excitation 16 μ W at 4.2 K; 10 μ W at 77 K; 5 μ W at 300 K

Thermal response time SD: typical <10 ms at 4.2 K, 100 ms at 77 K, 200 ms at 305 K; BR: 1 ms at 4.2 K, 13 ms at 77 K, 20 ms at 305 K

Use in radiation Recommended for use only in low level radiation – see Appendix B

Use in magnetic field Not recommended for use in magnetic field applications below 60 K. Low magnetic field dependence when used in fields up to 5 tesla above 60 K – see Appendix B

Reproducibility¹ \pm 10 mK at 4.2 K

¹ Short-term reproducibility data is obtained by subjecting sensor to repeated thermal shocks from 305 K to 4.2 K

Range of Use

	Minimum Limit	Maximum Limit
DT-670-SD	1.4 K	500 K
DT-670-CU-HT	1.4 K	500 K
DT-670E-BR	1.4 K	500 K

Temperature Response Data Table (typical)

	DT-670	
	V (volts)	dV/dT (mV/K)
1.4 K	1.64	-12.5
4.2 K	1.58	-31.6
10 K	1.38	-26.8
77 K	1.03	-1.73
305 K	0.560	-2.30

See Appendix G for expanded response table

Physical Specifications

	Mass	Lead type	Lead polarity	Sensor materials used
DT-670-SD	37 mg	2 – nickel and gold plated Kovar	positive lead on right with package lid up and leads towards user	Sapphire base with alumina body & lid. Molybdenum/manganese metallization on base and lid top with nickel and gold plating. Gold tin solder as hermetic seal.
DT-670E-BR (bare die)	72.7 μ g	none	positive connection made through bottom of chip; negative connection made on base pad on top of chip	Silicon chip with aluminum metallization on chip contacts.

Calibrated Accuracy

	Typical sensor accuracy ²
1.4 K	\pm 12 mK
4.2 K	\pm 12 mK
10 K	\pm 12 mK
77 K	\pm 22 mK
300 K	\pm 32 mK
500 K	\pm 50 mK

² $[(\text{Calibration uncertainty})^2 + (\text{reproducibility})^2]^{0.5}$ for more information see Appendices B, D, and E

Long-term Stability

	Use to 305 K ³	Use to 500 K ⁴
4.2 K	\pm 10 mK	\pm 40 mK
77 K	\pm 40 mK	\pm 100 mK
305 K	\pm 25 mK	\pm 50 mK
500 K	—	\pm 150 mK

³ Long-term stability data is obtained by subjecting sensor to 200 thermal shocks from 305 K to 77 K

⁴ Based on 670 h of baking at 500 K

Standard Curve DT-670 Tolerance Bands

	2 K to 100 K	100 K to 305 K	305 K to 500 K
Band A	\pm 0.25 K	\pm 0.5 K	\pm 0.5 K
Band A1	\pm 0.25 K	\pm 1.5% of temp	\pm 1.5% of temp
Band B	\pm 0.5 K	\pm 0.5 K	\pm 0.33% of temp
Band B1	\pm 0.5 K	\pm 1.5% of temp	\pm 1.5% of temp
Band C	\pm 1 K	\pm 1 K	\pm 0.50% of temp
	30 K to 100 K	100 K to 305 K	305 K to 500 K
Band D ⁵	\pm 0.25 K	\pm 0.30 K	\pm 0.10% of temp
Band E ⁵	\pm 0.25 K	\pm 0.25% of temp	\pm 0.25% of temp

⁵ For T < 30 K \pm 1.5 K

Typical Magnetic Field-Dependent Temperature Errors⁶ Δ T/T (%) at B (magnetic induction)

Package Base Parallel to Field B					
T(K)	1 T	2 T	3 T	4 T	5 T
4.2	-200	-300	-350	-400	-500
20	-10	-20	-25	-30	-40
40	-4	-6	-8	-10	-12
60	-0.5	-1	-2	-3	-3.5
80	< 0.1	-0.5	-0.8	-1.1	-1.5
300	<-0.1	<-0.1	<-0.1	<-0.1	<-0.1

Package Base Perpendicular to Field B					
T(K)	1 T	2 T	3 T	4 T	5 T
4.2	-8	-9	-11	-15	-20
20	-4	-5	-5	-5	-10
40	-1.5	-3	-4	-5	-5.5
60	-0.5	-0.7	-0.8	-1	-1.1
80	-0.1	-0.3	-0.5	-0.6	-0.7
300	<0.1	0.2	0.5	0.6	0.6

⁶ To minimize magnetic field-induced temperature errors, the sensor should be oriented so that the package base is perpendicular to the magnetic field flux lines – this results in the diode current being parallel to the magnetic field

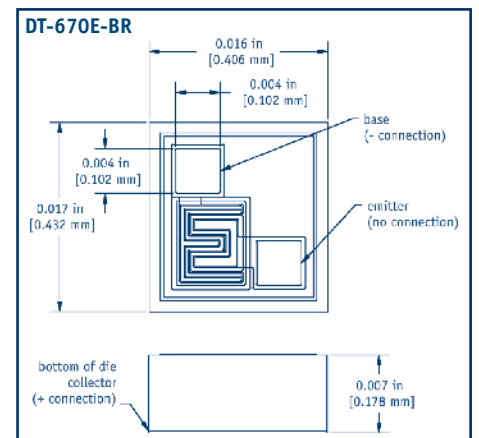
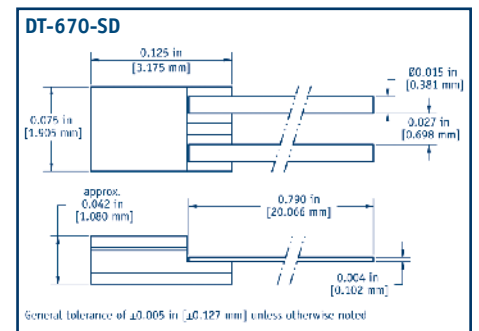

DT-670 Temperature Response Curve

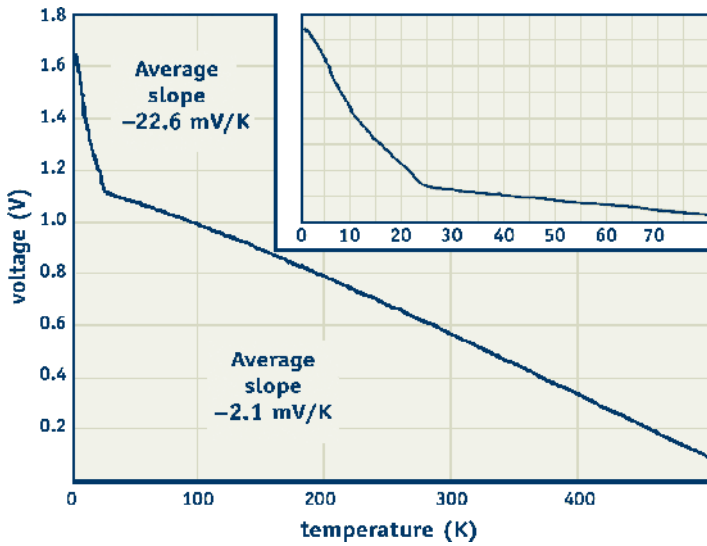

Curve DT-670 Tolerance Bands

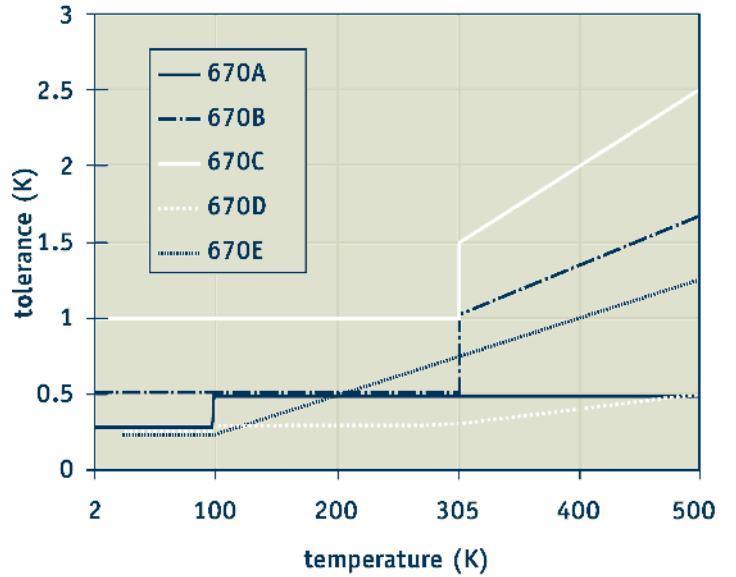

DT-670 Series Expanded Temperature Response Data Table

T (K)	Voltage (V)	dV/dT (mV/K)	T (K)	Voltage (V)	dV/dT (mV/K)	T (K)	Voltage (V)	dV/dT (mV/K)	T (K)	Voltage (V)	dV/dT (mV/K)
1.4	1.644290	-12.5	6.0	1.51541	-36.7	28.0	1.110421	-2.25	160.0	0.868518	-2.07
1.5	1.642990	-13.6	6.5	1.49698	-36.9	29.0	1.108261	-2.08	170.0	0.847659	-2.10
1.6	1.641570	-14.8	7.0	1.47868	-36.2	30.0	1.106244	-1.96	180.0	0.826560	-2.12
1.7	1.640030	-16.0	7.5	1.46086	-35.0	31.0	1.104324	-1.88	190.0	0.805242	-2.14
1.8	1.638370	-17.1	8.0	1.44374	-33.4	32.0	1.102476	-1.82	200.0	0.783720	-2.16
1.9	1.636600	-18.3	8.5	1.42747	-31.7	33.0	1.100681	-1.77	210.0	0.762007	-2.18
2.0	1.634720	-19.3	9.0	1.41207	-29.9	34.0	1.098930	-1.73	220.0	0.740115	-2.20
2.1	1.632740	-20.3	9.5	1.39751	-28.3	35.0	1.097216	-1.70	230.0	0.718054	-2.21
2.2	1.630670	-21.1	10.0	1.38373	-26.8	36.0	1.095534	-1.69	240.0	0.695834	-2.23
2.3	1.628520	-21.9	10.5	1.37065	-25.5	37.0	1.093878	-1.64	250.0	0.673462	-2.24
2.4	1.626290	-22.6	11.0	1.35820	-24.3	38.0	1.092244	-1.62	260.0	0.650949	-2.26
2.5	1.624000	-23.2	11.5	1.34632	-23.2	39.0	1.090627	-1.61	270.0	0.628302	-2.27
2.6	1.621660	-23.6	12.0	1.33499	-22.1	40.0	1.089024	-1.60	273.0	0.621141	-2.28
2.7	1.619280	-24.0	12.5	1.32416	-21.2	42.0	1.085842	-1.59	280.0	0.605528	-2.28
2.8	1.616870	-24.2	13.0	1.31381	-20.3	44.0	1.082669	-1.59	290.0	0.582637	-2.29
2.9	1.614450	-24.4	13.5	1.30390	-19.4	46.0	1.079492	-1.59	300.0	0.559639	-2.30
3.0	1.612000	-24.7	14.0	1.29439	-18.6	48.0	1.076303	-1.60	310.0	0.536542	-2.31
3.1	1.609510	-25.1	14.5	1.28526	-17.9	50.0	1.073099	-1.61	320.0	0.513361	-2.32
3.2	1.606970	-25.6	15.0	1.27645	-17.3	52.0	1.069881	-1.61	330.0	0.490106	-2.33
3.3	1.604380	-26.2	15.5	1.26794	-16.8	54.0	1.066650	-1.62	340.0	0.466760	-2.34
3.4	1.601730	-26.8	16.0	1.25967	-16.3	56.0	1.063403	-1.63	350.0	0.443371	-2.34
3.5	1.599020	-27.4	16.5	1.25161	-15.9	58.0	1.060141	-1.64	360.0	0.419960	-2.34
3.6	1.596260	-27.9	17.0	1.24372	-15.6	60.0	1.056862	-1.64	370.0	0.396503	-2.35
3.7	1.59344	-28.4	17.5	1.23596	-15.4	65.0	1.048584	-1.67	380.0	0.373002	-2.35
3.8	1.59057	-29.0	18.0	1.22830	-15.3	70.0	1.040183	-1.69	390.0	0.349453	-2.36
3.9	1.58764	-29.6	18.5	1.22070	-15.2	75.0	1.031651	-1.72	400.0	0.325839	-2.36
4.0	1.58465	-30.2	19.0	1.21311	-15.2	77.35	1.027594	-1.73	410.0	0.302161	-2.37
4.2	1.57848	-31.6	19.5	1.20548	-15.3	80.0	1.022984	-1.75	420.0	0.278416	-2.38
4.4	1.57202	-32.9	20.0	1.197748	-15.6	85.0	1.014181	-1.77	430.0	0.254592	-2.39
4.6	1.56533	-34.0	21.0	1.181548	-17.0	90.0	1.005244	-1.80	440.0	0.230697	-2.39
4.8	1.55845	-34.7	22.0	1.162797	-21.1	100.0	0.986974	-1.85	450.0	0.206758	-2.39
5.0	1.55145	-35.2	23.0	1.140817	-20.8	110.0	0.968209	-1.90	460.0	0.182832	-2.39
5.2	1.54436	-35.6	24.0	1.125923	-9.42	120.0	0.949000	-1.94	470.0	0.159010	-2.37
5.4	1.53721	-35.9	25.0	1.119448	-4.60	130.0	0.929390	-1.98	480.0	0.135480	-2.33
5.6	1.53000	-36.2	26.0	1.115658	-3.19	140.0	0.909416	-2.01	490.0	0.112553	-2.25
5.8	1.52273	-36.5	27.0	1.112810	-2.58	150.0	0.889114	-2.05	500.0	0.090681	-2.12

PACKAGING OPTIONS

For information on mounting adapters available for use with the SD package, see page 25.

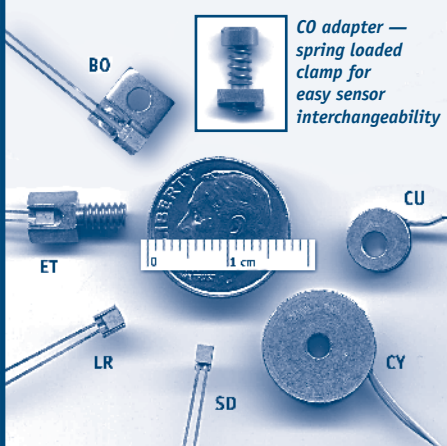

CO adapter — spring loaded clamp for easy sensor interchangeability

To add length to sensor leads (SMOD), see page 28.

Upgrade Conversion Chart

	From:	To:
Sensor	DT-470	DT-670
Band	11	A
	11A	A1
	12	B
	12A	B1
	13	C



See the appendices for a detailed description of:

- Installation
- Uncalibrated sensors
- SoftCal™
- Calibrated sensors
- CalCurve™
- Sensor packages

Ordering Information

Uncalibrated sensor

Step 1: Choose diode series, for example DT-670.

Step 2: Choose tolerance band (if applicable), for example DT-670A.

Step 3: Choose package or mounting adapter – if ordering adapter, substitute the adapter suffix for the SD suffix, for example DT-670A-CU.

Calibrated sensor

Step 1: Choose diode series, for example DT-670.

Step 2: Choose package or mounting adapter – if ordering adapter, substitute the adapter suffix for the SD suffix, for example DT-670-CU.

Step 3: Specify the calibration range suffix code after the model number and package suffix, for example DT-670-CU-1.4L.

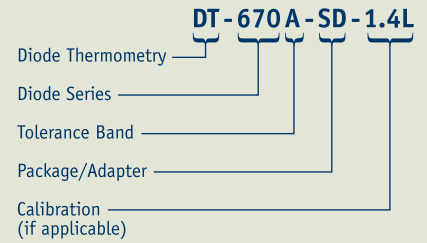

DT-670

Calibration Range Suffix Codes

Numeric figure is the low end of the calibration

Letters represent the high end: D=100 K, L=325 K, H=500 K

Model number	Uncal	1.4D	1.4L	1.4H	4D	4L	4H
DT-670A-SD	■						
DT-670A1-SD	■						
DT-670B-SD	■						
DT-670B1-SD	■						
DT-670C-SD	■						
DT-670D-SD	■						
DT-670-SD	■	■	■	■	■	■	■

Mounting adapters are available for use with the SD package – replace SD suffix with mounting adapter suffix

CO	■	■	■	■	■	■	■
CU, LR, CY, ET, BO, MT	■	■	■		■	■	
CU-HT	■	■	■	■	■	■	■
DT-670E-BR-10	■	— bare chip silicon diode sensor, quantity 10					

Note: upper temperature limit package dependent – see Sensor Packages section
Other packaging available by special order – please consult Lake Shore

Accessories available for sensors

- SN-CO-C1 CO style sensor clamps for SD package
- ECRIT Expanded interpolation table
- 8000 Calibration report on CD-ROM
- COC-SEN Certificate of conformance

Accessories suggested for installation – see Accessories section for full descriptions

- Stycast® epoxy
- Apiezon® grease
- 90% Pb, 10% Sn solder
- Indium solder
- VGE-7031 varnish
- Phosphor bronze wire
- Manganin wire

