

Techniques for stereo volume control (with optional compressor/limiter)

This design note includes techniques for implementing:

1. Stereo control of a VCA with a single, linear potentiometer
2. Multiple adjustment slope across the range
3. Push-button control to change adjustment slope
4. Integrating a compressor limiter into the volume control

Figure 1 shows two [THAT2181](#) VCAs controlled by a single volume control potentiometer. Given a supply voltage of $\pm 15V$ and a VCA control voltage constant of $6.1mV/dB$, the potentiometer span is calculated as follows:

$$PotSpan = \frac{30V \times \left(\frac{51 \Omega}{51 \Omega + 3.01 k\Omega} \right)}{6.1 mV/dB} = 81.9 dB \Rightarrow \pm 40.9 dB$$

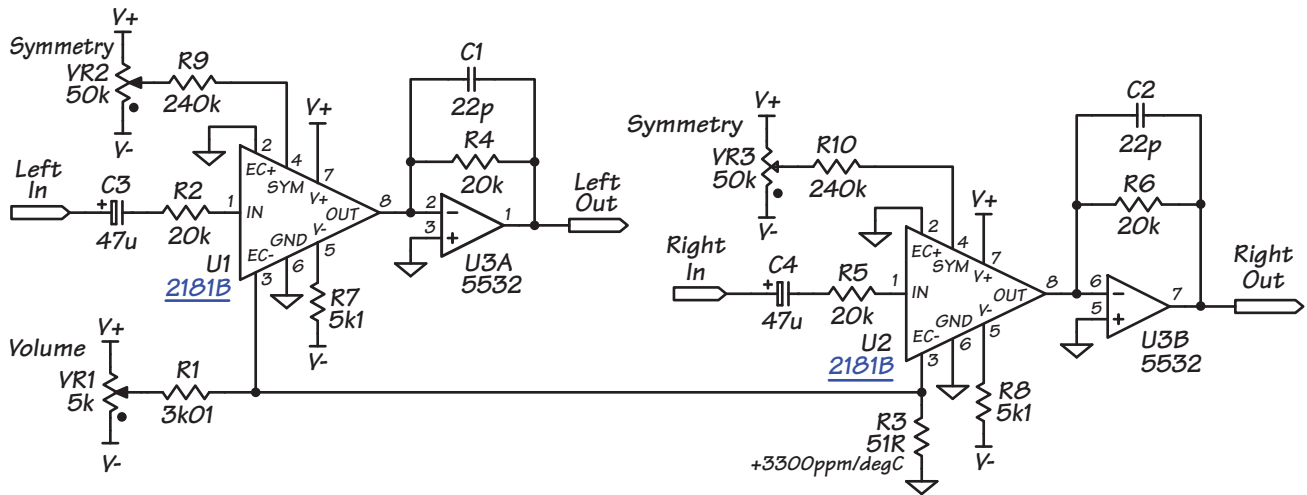

Figure 1: Controlling 2 channels with a single, linear volume control potentiometer

There will be some additional distortion due to the increased control port impedance, but using an op-amp follower to buffer the control port will eliminate this problem. Control port linearity could result in a worst case mis-match of 2.4 dB at $-60 dB$ gain, but this is extremely unlikely. A more realistic cause of error would be thermal mis-matches between devices. This problem can be greatly reduced by careful layout. First, both [THAT2181](#) VCAs should be placed side-by-side (touching if possible), with corresponding pins aligned (pin 1 to pin 1, etc.) Second, keep these devices away from other devices dissipating significant amounts of power, as those devices can cause thermal gradients which can result in thermal mismatches between VCAs. If the designer knows the direction of gradients and/or convection currents in the housing, the VCAs should be aligned with that gradient to eliminate temperature differentials between parts. One final note on this circuit: R3 should be a $+3300 ppm/degC$ resistor to properly temperature compensate the VCAs' control.

Techniques for stereo volume control (with optional compressor/limiter)

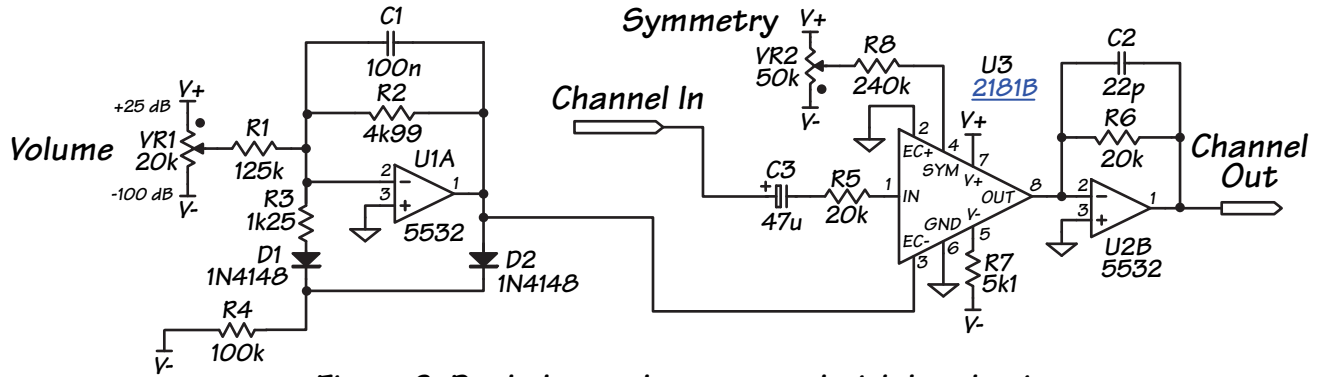

Figure 2: Dual slope volume control with breakpoint

Figure 2 shows a circuit that uses a linear potentiometer, but has different volume control slopes on each of the 2 halves of the potentiometer's range. While the output of U1A is positive, D1 is reverse biased, and the gain of this stage is:

$$\text{Gain} = \frac{-R2}{R1} = \frac{-4.99k}{125k} = -.04$$

which results in a volume swing of 0 to -100 dB as the potentiometer is rotated from its center to CCW. While the output of U1A is negative, D1 is forward biased, and the gain of this stage is:

$$\text{Gain} = \frac{-R2||R3}{R1} = \frac{-999}{125k} = -.008$$

which results in a volume swing of 0 to 25 dB as the potentiometer is rotated from its center to CW. Figure 3 shows a SPICE simulation of this circuit with the input to R1 swept from -15V to +15V. Note the change of slope as the input, plotted against the x axis, is swept from -15V to +15V. Note also, that D2 properly compensates the temperature coefficient of D1.

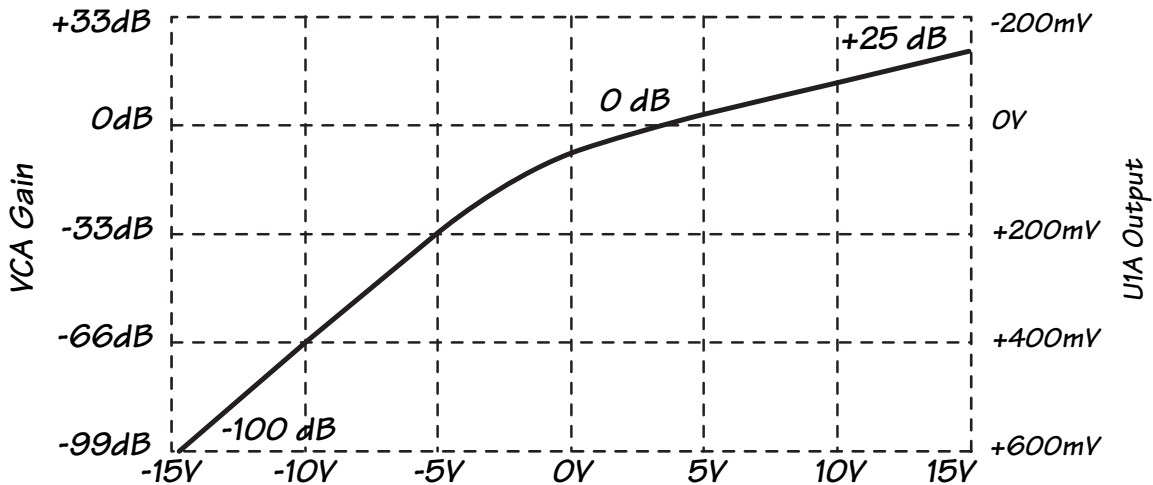

Figure 3: SPICE simulation of breakpoint performance

Techniques for stereo volume control (with optional compressor/limiter)

The circuit in Figure 4 demonstrates how to make the span of the volume control potentiometer selectable with a switch. The swing of the volume control potentiometer is calculated in the same way as for the circuit in Figure 1, except that for low sensitivity, we use a 12.1 kΩ resistor for R1 in the divider equation, and for high sensitivity, we use the total equivalent resistance of the parallel combination of R1 and R4.

$$\text{PotSpanHighSens} = \frac{30V \times \left(\frac{51 \Omega}{51 \Omega + 3.01 \text{ k}\Omega} \right)}{6.1 \text{ mV/dB}} = 81.9 \text{ dB} \Rightarrow \pm 40.9 \text{ dB}$$

$$\text{PotSpanLowSens} = \frac{30V \times \left(\frac{51 \Omega}{51 \Omega + 12.1 \text{ k}\Omega} \right)}{6.1 \text{ mV/dB}} = 20.6 \text{ dB} \Rightarrow \pm 10.3 \text{ dB}$$

C3 smoothes the step when SW1 is closed.

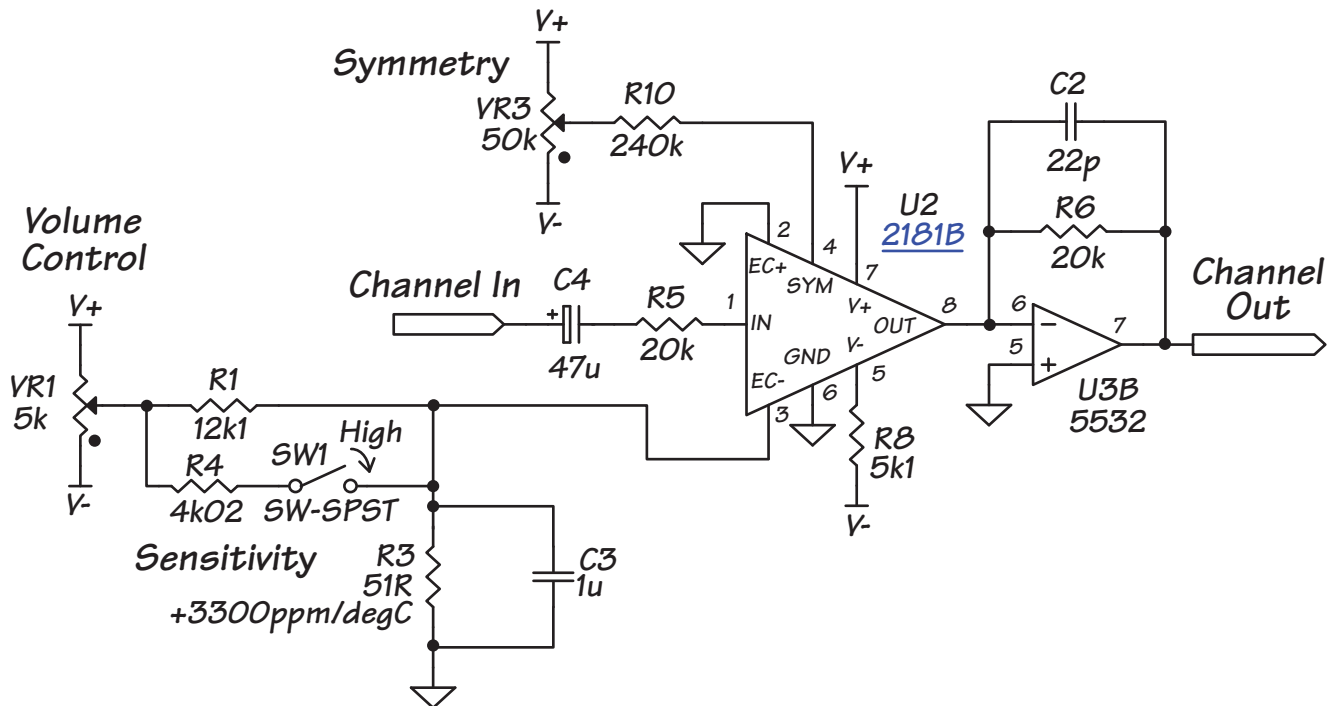

Figure 4: Volume control with switch selectable sensitivity

Techniques for stereo volume control (with optional compressor/limiter)

Figure 5 shows the correct method for connecting [THAT2252](#) RMS detectors in parallel. Using this connection in stereo applications will prevent "image shifting" due to one channel compressing while the other is not, which can be a problem in stereo systems with 2 detectors. This technique requires that the 0 dB reference point for both detectors be the same. Since there is a 3dB tolerance on $linO$, VR1 is provided to adjust this parameter.

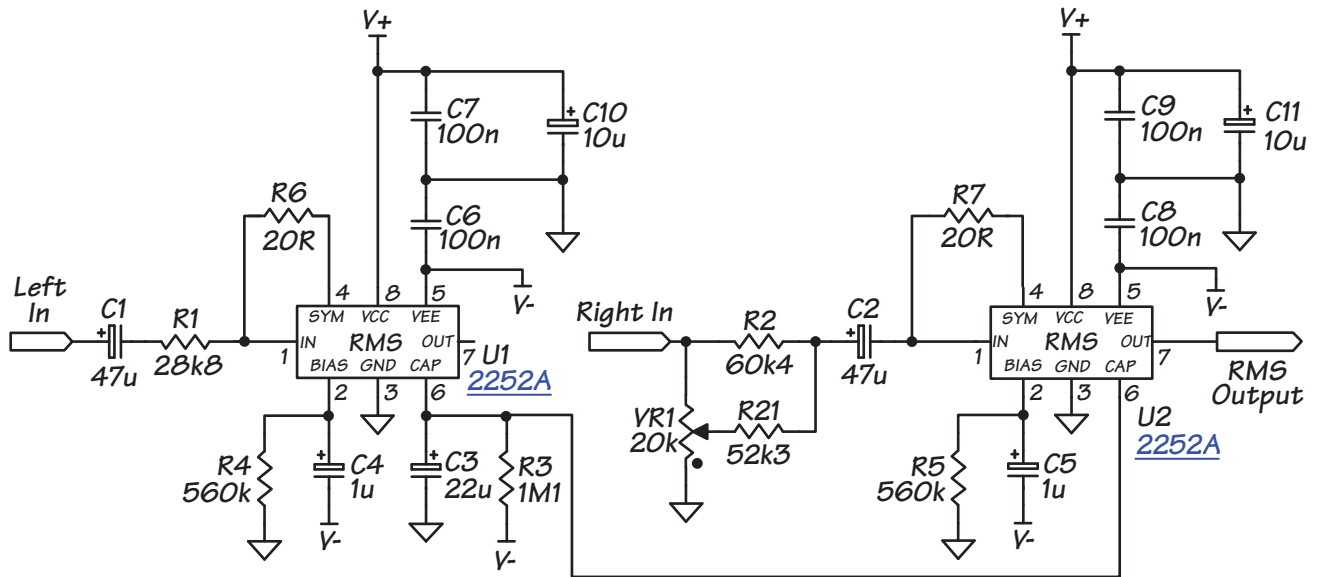

Figure 5: THAT2252 RMS detectors connected for true RMS power summing

The schematic in Figure 6 is titled VCA Volume Control w/ Compressor. This schematic shows a compressor/limiter which also has the dual slope volume control with breakpoint shown in Figure 2.

Also in the Figure 6 schematic, the RMS detector is configured to have a 0 dB reference point (the input level which results in 0 volts out) of -10 dBu. This level is easily changed by adjusting R7. R11 is configured to by-pass the detectors symmetry adjustment. This is the same connection which is implemented internally on the [THAT4301](#). Otherwise, the detector is designed per the [THAT2252 datasheet](#) recommendations.

Techniques for stereo volume control (with optional compressor/limiter)

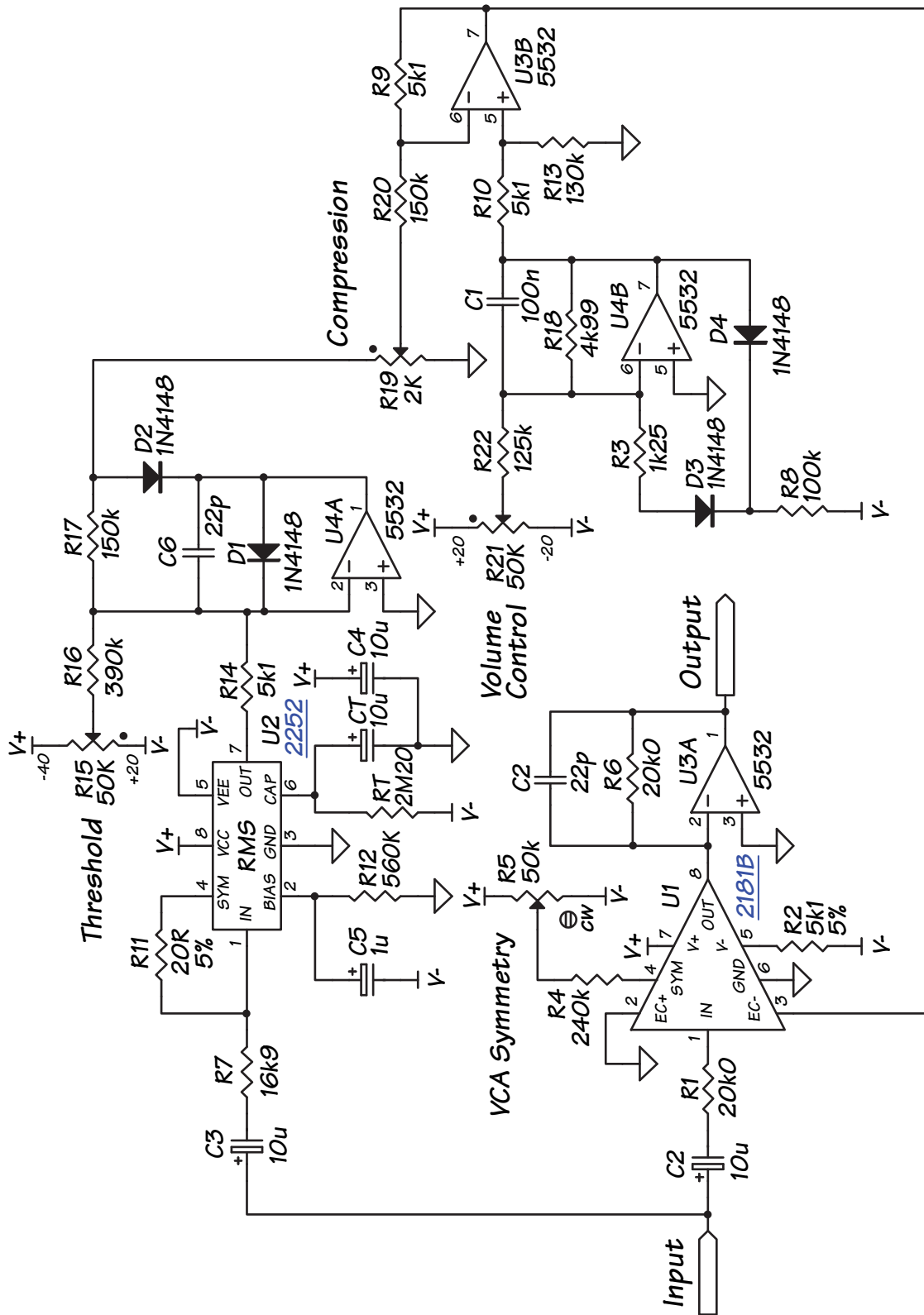

Figure 6: VCA Volume Control w/ Compressor