

---

# Chapter 5

## Protection Circuit Design

---

### CONTENTS

### Page

1. Short circuit (overcurrent) protection .....	5-2
2. Overvoltage protection .....	5-6

This section explains the protection circuit design.

---

## 1 Short circuit (overcurrent) protection

### 1.1 Short circuit withstand capability

In the event of a short circuit, first the IGBT's collector current will rise, once it has reached a certain level, the C-E voltage will spike. Depending on the device's characteristics, during the short-circuit, the collector current can be kept at or below a certain level, however the IGBT will still continue to be subjected to a heavy load (high voltage and high current).

Therefore, this condition must be removed as soon as possible. The amount of time allowed between the start of a short circuit until the current is cut off, is limited by the IGBT's short circuit withstand capability.

The short-circuit withstand capability, as illustrated in Fig. 5-1. It is determined by the amount of time it takes from the start of the short-circuit current until the module is destroyed. The withstand capability of the N series IGBTs is as follows:

Short-circuit withstand capability: 10 $\mu$ s minimum

#### < Conditions >

- $V_{CC}$  600V series:  $E_d(V_{CC})=400V$   
1200V series:  $E_d(V_{CC})=800V$
- $V_{GE} = 15V$
- $R_G$ : Standard  $R_G$  value (from the specifications)
- $T_j = 125^\circ C$

In general, the higher the supply voltage ( $E_d$ ) or temperature ( $T_j$ ) rises, the lower the short-circuit withstand capability.

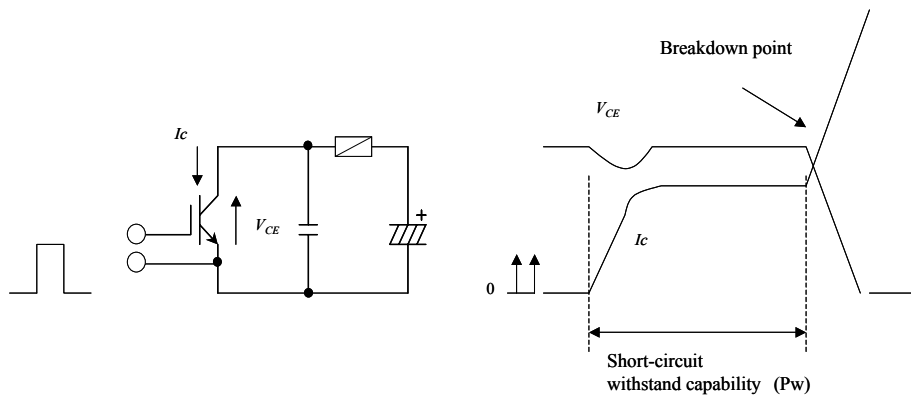
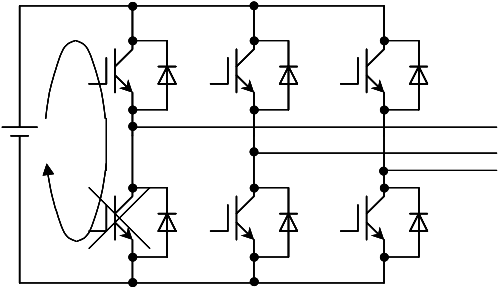
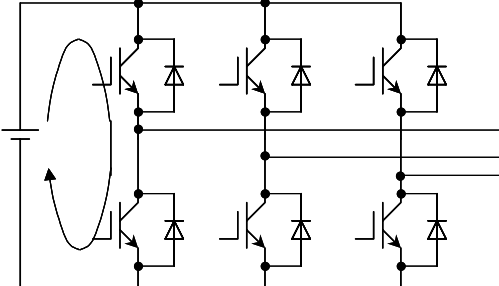
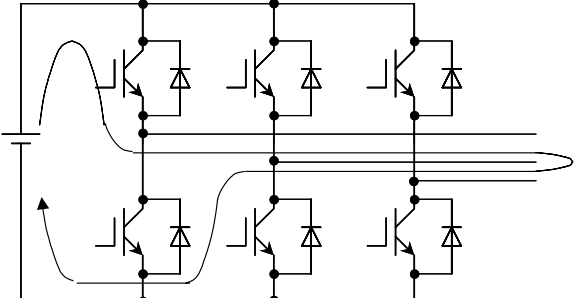
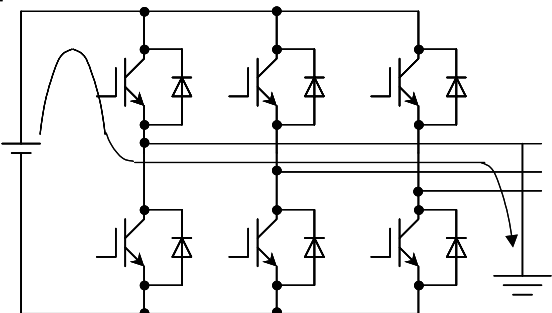

Fig. 5-1 Measuring circuit and waveform

### 1.2 Short-circuit modes and causes

Table 5-1 lists the short-circuit modes and causes that occur in inverters.

Table 5-1 Short circuit mode and cause

Short circuit mode	Cause
<p>Arm short circuit</p> 	<p>Transistor or diode destruction</p>
<p>Series arm short circuit</p> 	<p>Faulty control/drive circuit or noise induce malfunction</p>
<p>Short in output circuit</p> 	<p>Miswiring or dielectric breakdown of load</p>
<p>Ground fault</p> 	<p>Miswiring or dielectric breakdown of load</p>

### 1.3 Short-circuit (overcurrent) detection

#### 1) Detection in the circuit

As stated previously, in the event of a short-circuit, the IGBT must be disabled as soon as possible. Therefore, the time from overcurrent detection to the complete turn-off in each circuit must be as short as possible.

Since the IGBT turns off very quickly, if the overcurrent is shut off using an ordinary drive signal, the collector-emitter voltage will rise due to the inductive kick, and the IGBT may be destroyed by overvoltage (RBSOA destructions). Therefore, it is recommended that when cutting off the overcurrent that the IGBT be turned off gently (Soft turn-off).

Figure 5-2 shows the insertion methods for overcurrent detectors, and Table 5-2 lists the features of the various methods along with their detection possibilities. After determining what kind of protection is necessary, select the most appropriate form of detection.

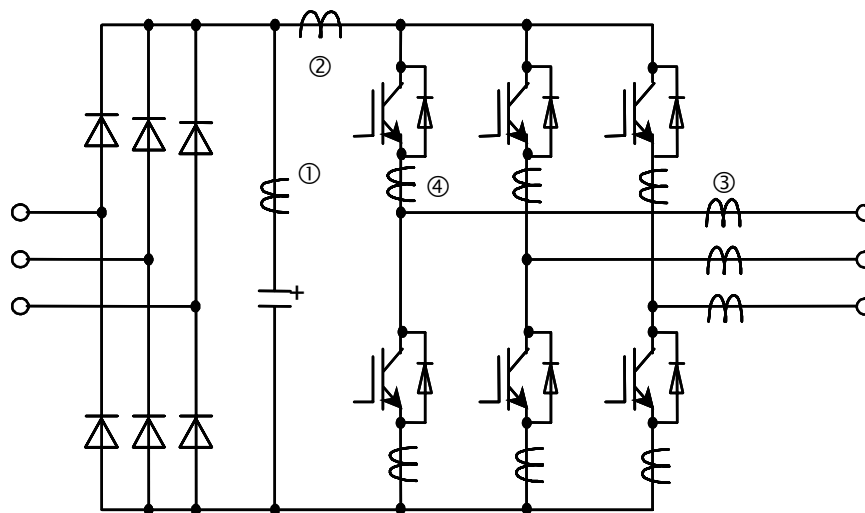

Fig. 5-2 Overcurrent detector insertion methods

**Table 5-2 Overcurrent detector insertion positions and function**

Detector insertion position	Features	Detection function
Insertion in line with smoothing capacitor Fig. 5-2/①	<ul style="list-style-type: none"> <li>• AC current transformer available</li> <li>• Low detection precision</li> </ul>	<ul style="list-style-type: none"> <li>• Arm short-circuit</li> <li>• Short in output circuit</li> <li>• Series arm short-circuit</li> <li>• Ground fault</li> </ul>
Insertion at inverter input Fig. 5-2/②	<ul style="list-style-type: none"> <li>• Necessary to use DC current transformer</li> <li>• Low detection precision</li> </ul>	<ul style="list-style-type: none"> <li>• Arm short-circuit</li> <li>• Short in output circuit</li> <li>• Series arm short-circuit</li> <li>• Ground fault</li> </ul>
Insertion at inverter output Fig. 5-2/③	<ul style="list-style-type: none"> <li>• AC current transformer available for high frequency output equipment</li> <li>• High detection precision</li> </ul>	<ul style="list-style-type: none"> <li>• Short in output circuit</li> <li>• Ground fault</li> </ul>
Insertion in line with switches Fig. 5-2/④	<ul style="list-style-type: none"> <li>• Necessary to use DC current transformer</li> <li>• High detection precision</li> </ul>	<ul style="list-style-type: none"> <li>• Arm short-circuit</li> <li>• Short in output circuit</li> <li>• Series arm short-circuit</li> <li>• Ground fault</li> </ul>

**2) Detecting using  $V_{CE(sat)}$**

This method can protect against all of the short-circuit types listed in Table 5-1. Since all operations from overcurrent detection to protection are done on the drive circuit side, this offers the fastest protection possible. A short-circuit protection schematic, based in  $V_{CE(sat)}$  detection, is shown in Fig. 5-3.

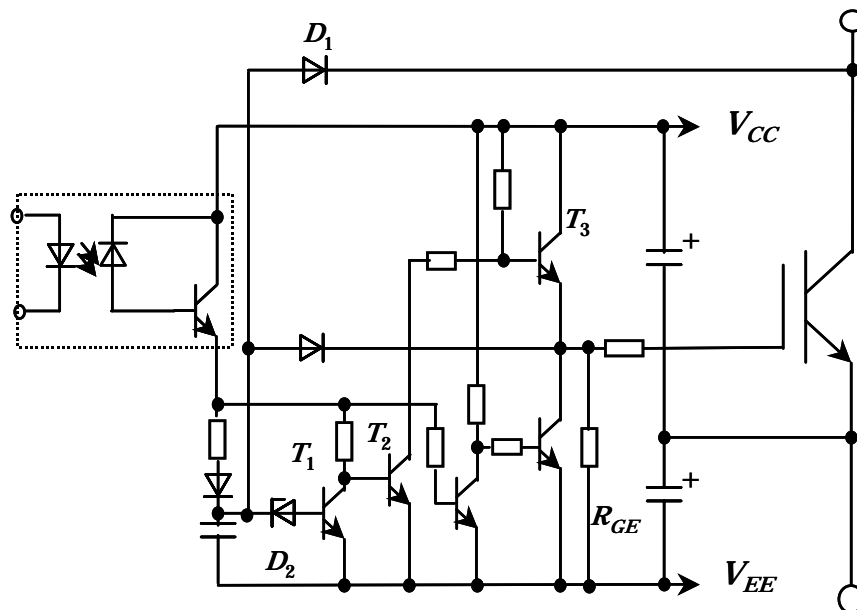

**Fig. 5-3 Short-circuit protection schematic based in  $V_{CE(sat)}$  detection**

This circuit uses  $D_1$  to constantly monitor the collector-emitter voltage, so if during operation the IGBT's collector-emitter voltage rises above the limit at  $D_2$ , then a short-circuit condition will be detected and  $T_1$  will be switched on while  $T_2$  and  $T_3$  are switched off. At this time, the accumulated charge at the gate is slowly released through the  $R_{GE}$ , so a large voltage spike is prevented when the IGBT is turned off.

Fuji Electric's gate driver hybrid IC<sub>S</sub> (model EXB840, 841) have the same kind of protective circuit built in, thereby simplifying the drive circuit design. For more details, refer to Chapter 7 "Drive Circuit Design". Fig. 5-4 shows an IGBT waveform during short circuit protection.

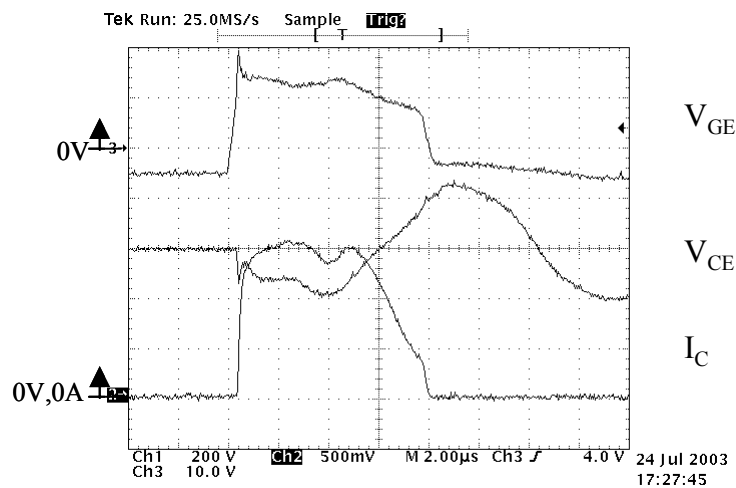

2MBI300UD-120

$E_d=600\text{V}$ ,  $V_{GE}=+15\text{V}$ ,  $-5\text{V}$  (EXB841),  $R_G=3.3\Omega$ ,  $T_j=125^\circ\text{C}$

$V_{CE}=200\text{V/div}$ ,  $I_C=250\text{A}$ ,  $V_{GE}=10\text{V/div}$ ,  $t=2\mu\text{s/div}$

**Fig. 5-4 Waveforms during short circuit protection**

## 2 Overvoltage protection

### 2.1 Overvoltage causes and their suppression

#### 1) Overvoltage causes

Due to the high switching speed of IGBTs, at turn-off or during FWD reverse recovery, the current change rate ( $di/dt$ ) is very high. Therefore the circuit wiring inductance to the module can cause a high turn-off surge voltage ( $V=L(di/dt)$ ).

At an example, using the IGBT's waveform at turn-off we will introduce the causes and methods of their suppression, as well as illustrate a concrete example of a circuit (using an IGBT and FWD together).

To demonstrate the turn-off surge voltage, a simplified chopper circuit is shown in Fig. 5-5, and the IGBT turn-off voltage and current waveforms are shown in Fig. 5-6.

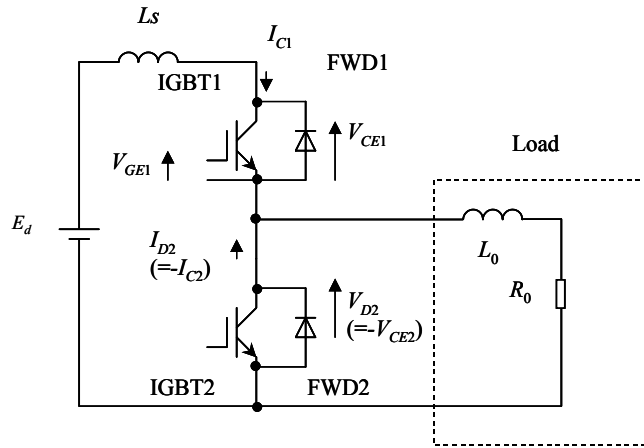

$E_d$ : DC supply voltage,  $L_S$ : Main circuit wiring inductance, Load:  $L_0, R_0$

Fig. 5-5 Chopper circuit

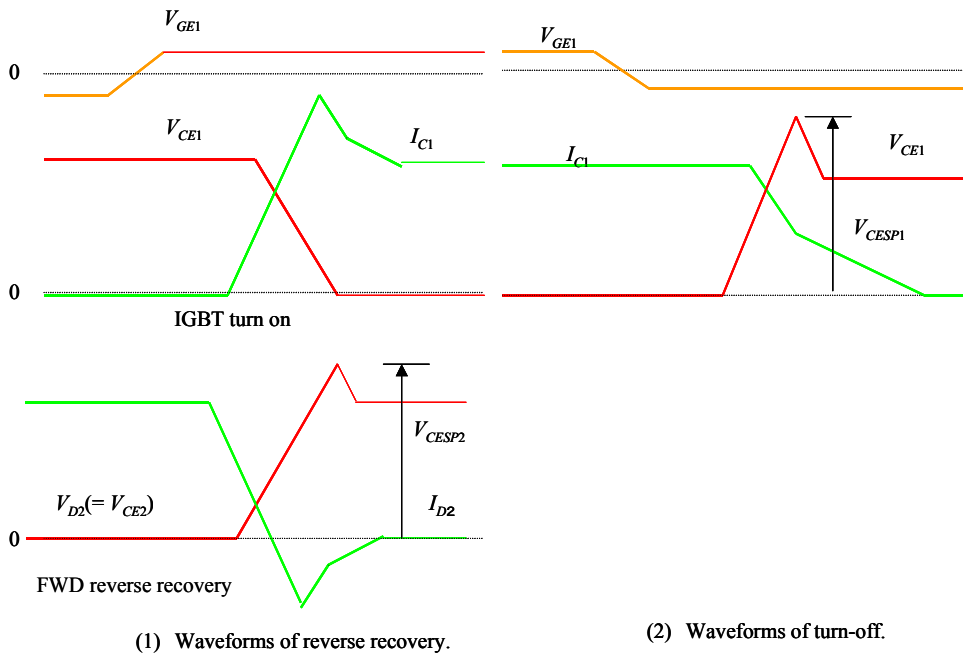

Fig. 5-6 Switching waveforms

The turn-off surge voltage peak  $V_{CESP}$  can be calculated as follows:

$$V_{CESP} = E_d + (-L_S \cdot dI_c / dt) \dots\dots\dots ①$$

$dI_c/dt$ : Maximum collector current change rate at turn-off

If  $V_{CESP}$  exceeds the IGBT's C-E ( $V_{CES}$ ) rating, then the module will be destroyed.

## 2) Overvoltage suppression methods

Several methods for suppressing turn-off surge voltage, the cause for overvoltage, are listed below:

- a. Control the surge voltage by adding a protection circuit (snubber circuit) to the IGBT.  
Use a film capacitor in the snubber circuit, place it as close as possible to the IGBT in order to bypass high frequency surge currents.
- b. Adjust the IGBT drive circuit's  $V_{GE}$  or  $R_G$  in order to reduce the  $di/dt$  value. (Refer to Chapter 7, "Drive Circuit Design".)
- c. Place the electrolytic capacitor as close as possible to the IGBT in order to reduce the effective inductance of the wiring. Use a low impedance capacitor.
- d. To reduce the inductance of the main as well as snubber circuit's wiring, use thicker and shorter wires. It is also very effective to use laminated copper bars in the wiring.

## 2.2 Types of snubber circuits and their features

Snubber circuits can be classified into two types: individual and lump. Individual snubber circuits are connected to each IGBT, while lump snubber circuits are connected between the DC power-supply bus and the ground for centralized protection.

### 1) Individual snubber circuits

Examples of typical individual snubber circuits are listed below.

- a) RC snubber circuit
- b) Charge and discharge RCD snubber circuit
- c) Discharge-suppressing RCD snubber circuit

Table 5-3 shows the schematic of each type of individual snubber circuit, its features, and an outline of its main uses.

### 2) Lump snubber circuits

Examples of typical snubber circuits are listed below.

- a) C snubber circuits
- b) RCD snubber circuits

Lump snubber circuits are becoming increasingly popular due to circuit simplification.

Table 5-4 shows the schematic of each type of lump snubber circuit, its features, and an outline of its main applications. Table 5-5 shows the capacity selection of a C type snubber circuit. Fig. 5-7 shows the current and voltage turn-off waveforms for an IGBT connected to a lump snubber circuit.

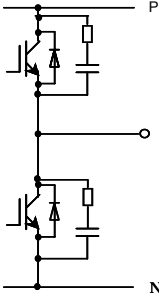
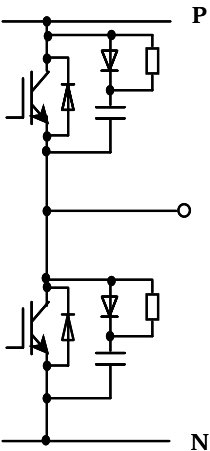
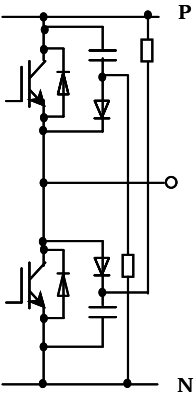

**Table 5-3 Individual snubber circuits**

Snubber circuit schematic	Circuit features (comments)	Main application
<p>RC snubber circuit</p> 	<ul style="list-style-type: none"> <li>• The effect on turn-off surge voltage suppression is great.</li> <li>• Perfect for chopper circuits</li> <li>• When applied to large capacity IGBTs, the snubber's resistance must be low. Consequently however, the above makes the load conditions at turn-on more severe.</li> </ul>	<p>Arc welder</p> <p>Switching power supply</p>
<p>Charge and discharge RCD snubber circuit</p> 	<ul style="list-style-type: none"> <li>• The effect on turn-off surge voltage is moderate.</li> <li>• As opposed to the RC snubber circuit, a snubber diode has been added. This allows the snubber's resistance to increase and consequently avoids the IGBT load conditions at turn-on problem.</li> <li>• Since the power dissipation loss of this circuit (primarily caused by the snubber's resistance) is much greater than that of a discharge suppressing snubber circuit, it is not considered suitable for high frequency switching applications.</li> <li>• The power dissipation loss caused by the resistance of this circuit can be calculated as follows:</li> </ul> $P = \frac{L \cdot I_o^2 \cdot f}{2} + \frac{C_s \cdot E_d^2 \cdot f}{2}$ <p>L: Wiring inductance of main circuit,  <i>I</i><sub>o</sub>: Collector current at IGBT turn-off,  <i>C</i><sub>s</sub>: Capacitance of snubber capacitor,  <i>E</i><sub>d</sub>: DC supply voltage,  <i>f</i>: Switching frequency</p>	
<p>Discharge suppressing RCD snubber circuit</p> 	<ul style="list-style-type: none"> <li>• The effect on turn-off surge voltage is small</li> <li>• Suitable for high-frequency switching</li> <li>• Power dissipation loss caused by snubber circuit is small.</li> <li>• The power dissipation loss caused by the resistance of this circuit can be calculated as follows:</li> </ul> $P = \frac{L \cdot I_o^2 \cdot f}{2}$ <p>L: Wiring inductance of main circuit  <i>I</i><sub>o</sub>: Collector current at IGBT turn-off  <i>f</i>: Switching frequency</p>	<p>Inverter</p>

**Table 5-4 Lump snubber circuits**

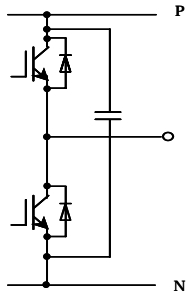
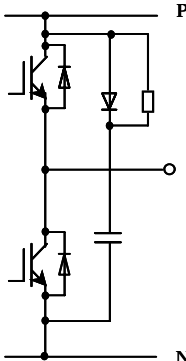
Snubber circuit schematic	Circuit features (comments)	Main application
<p>C snubber circuit</p> 	<ul style="list-style-type: none"> <li>This is the simplest circuit</li> <li>The LC resonance circuit, which consists of a main circuit inductance coil and snubber capacitor, may cause the C-E voltage to oscillate.</li> </ul>	Inverter
<p>RCD snubber circuit</p> 	<ul style="list-style-type: none"> <li>If the wrong snubber diode is used, a high spike voltage will be generated and the output voltage will oscillate at the diodes reverse recovery.</li> </ul>	Inverter

**Table 5-5 Guidelines for determining lump C snubber circuit capacity**

Module rating	Item	Drive conditions* <sup>1</sup>		Main circuit wiring inductance (μH)	Capacitance of snubber capacitance Cs (μF)
		-V <sub>GE</sub> (V)	R <sub>G</sub> (Ω)		
600V	50A	15 max.	68 min.	-	0.47
	75A		47 min.		
	100A		33 min.		
	150A		24 min.	0.2 max.	1.5
	200A		16 min.	0.16 max.	2.2
	300A		9.1 min.	0.1 max.	3.3
	400A		6.8 min.	0.08 max.	4.7
1200V	50A	15 max.	22 min.	-	0.47
	75A		9.1 min.		
	100A		5.6 min.		
	150A		4.7 min.	0.2 max.	1.5
	200A		3.0 min.	0.16 max.	2.2
	300A		2.0 min.	0.1 max.	3.3

\*<sup>1</sup>: Typical standard gate resistance of U series IGBT is shown.

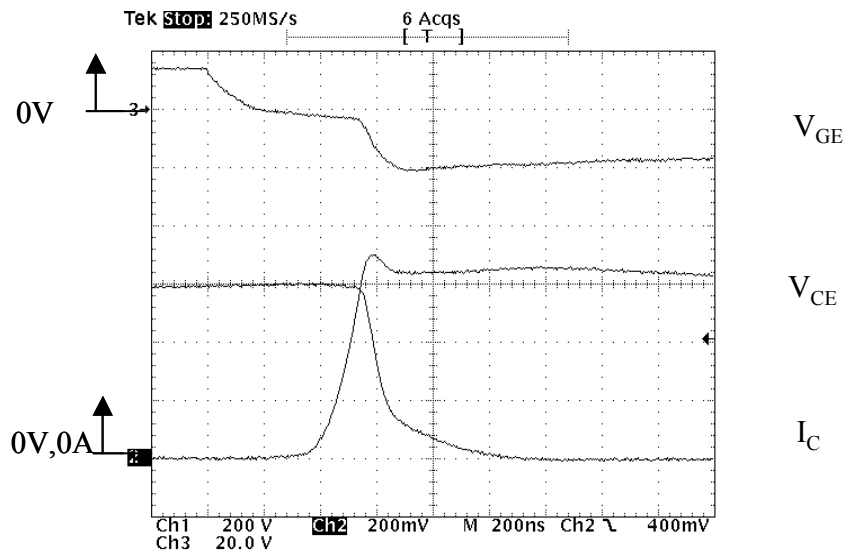

6MBI300U-120

$E_d=600V$ ,  $V_{GE}=\pm 15V$ ,  $I_c=300A$ ,  $R_G=2.2\Omega$ ,  $T_j=125C$ ,  $L_s=65nH$

$V_{CE}:200V/div$ ,  $I_C:100A/div$ ,  $V_{GE}:20V/div$ ,  $t:200ns/div$

Fig. 5-7 Current and voltage waveforms of IGBT in lump snubber circuit at turn-off

### 2.3 Discharge-suppressing RCD snubber circuit design

The discharge suppressing RCD can be considered the most suitable snubber circuit for IGBTs. Basic design methods for this type of circuit are explained in the following.

#### 1) Study of applicability

Figure 5-8 is the turn-off locus waveform of an IGBT in a discharge-suppressing RCD snubber circuit.

Fig. 5-9 shows the IGBT current and voltage waveforms at turn-off.

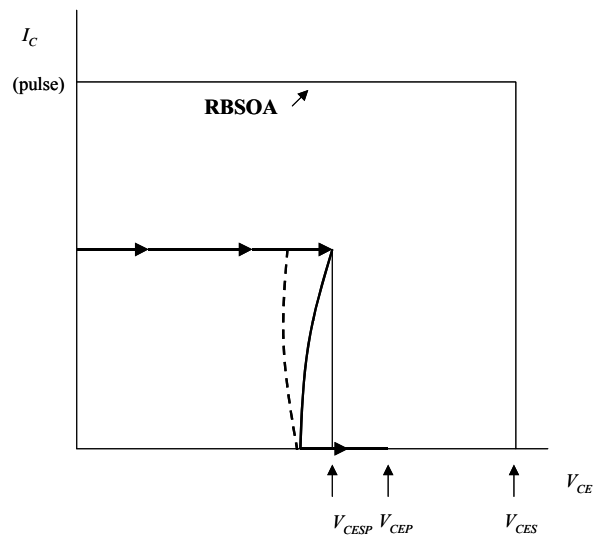

Fig. 5-8 Turn-off locus waveform of IGBT

The discharge-suppressing RCD snubber circuit is activated when the IGBT C-E voltage starts to exceed the DC supply voltage. The dotted line in diagram Fig. 5-8 shows the ideal operating locus of an IGBT. In an actual application, the wiring inductance of the snubber circuit or a transient forward voltage drop in the snubber diode can cause a spike voltage at IGBT turn-off. This spike voltage causes the sharp-cornered locus indicated by the solid line in Fig. 5-8.

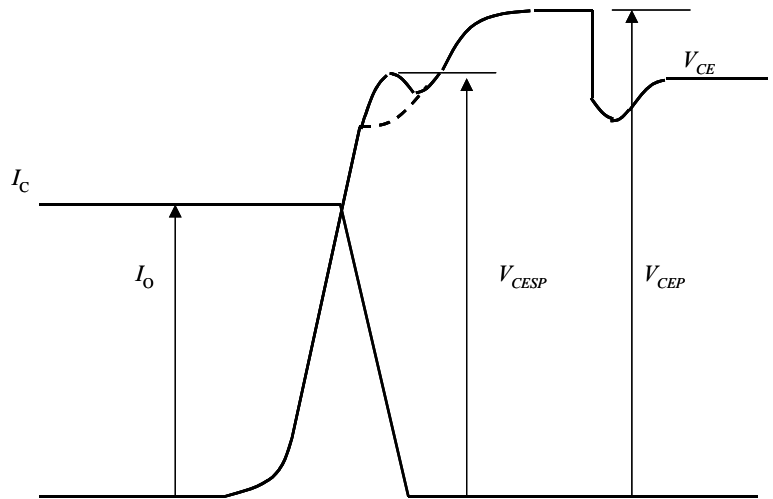

Fig. 5-9 Voltage and current waveforms at turn-off

The discharge-suppressing RCD snubber circuits applicability is decided by whether or not the IGBTs operating locus is within the RBSOA at turn-off.

The spike voltage at IGBT turn-off is calculated as follows:

$$V_{CESP} = Ed + V_{FM} + (-L_s \cdot dI_c / dt) \dots\dots\dots ②$$

Ed: Dc supply voltage

$V_{FM}$ : Transient forward voltage drop in snubber diode

The reference values for the transient forward voltage drop in snubber diodes is as follows:

600V class: 20 to 30V

1200V class: 40 to 60V

$L_s$ : Snubber circuit wiring inductance

$dI_c/dt$ : Maximum collector current change rate a IGBT turn-off

**2) Calculating the capacitance of the snubber capacitor (Cs)**

The necessary capacitance of a snubber capacitor is calculated as follows:

$$C_s = \frac{L \cdot I_o^2}{(V_{CEP} - Ed)^2} \dots\dots\dots ③$$

L: Main circuit wiring inductance

$I_o$ : Collector current at IGBT turn-off

$V_{CEP}$ : Snubber capacitor peak voltage

Ed: DC supply voltage

$V_{CEP}$  must be limited to less than or equal to the IGBT C-E withstand voltage.

**3) Calculating Snubber resistance (Rd)**

The function required of snubber resistance is to discharge the electric charge accumulated in the

snubber capacitor before the next IGBT turn-off.

To discharge 90% of the accumulated energy by the next IGBT turn-off, the snubber resistance must be as follows:

$$R_s \leq \frac{1}{2.3 \cdot C_s \cdot f} \dots\dots\dots \textcircled{4}$$

f: Switching frequency

If the snubber resistance is set too low, the snubber circuit current will oscillate and the peak collector current at the IGBT turn-off will increase. Therefore, set the snubber resistance in a range below the value calculated in the equation.

Irrespective of the resistance, the power dissipation loss P (Rs) is calculated as follows:

$$P(R_s) = \frac{L \cdot I_o^2 \cdot f}{2} \dots\dots\dots \textcircled{5}$$

#### 4) Snubber diode selection

A transient forward voltage drop in the snubber diode is one factor that can cause a spike voltage at IGBT turn-off.

If the reverse recovery time of the snubber diode is too long, then the power dissipation loss will also be much greater during high frequency switching. If the snubber diode's reverse recovery is too hard, then the IGBT C-E voltage will drastically oscillate.

Select a snubber diode that has a low transient forward voltage, short reverse recovery time and a soft recovery.

#### 5) Snubber circuit wiring precautions

The snubber circuit's wiring inductance is one of the main causes of spike voltage, therefore it is important to design the circuit with the lowest inductance possible.

### 2.4 Example of characteristic of surge voltage

The characteristic of the surge voltage at the turn-off for the U series IGBT (6MBI450U-120) is shown in Fig. 5-10. The larger the turn-off current the greater the turn-off surge voltage. Fig. 5-11 shows the surge voltage of the FWD for the same U series IGBT in reverse recovery. In general, reverse recovery surge voltage becomes large when collector current is approx. 2 to 20% of maximum Ic rating. Suppress recovery surge within RBSOA.

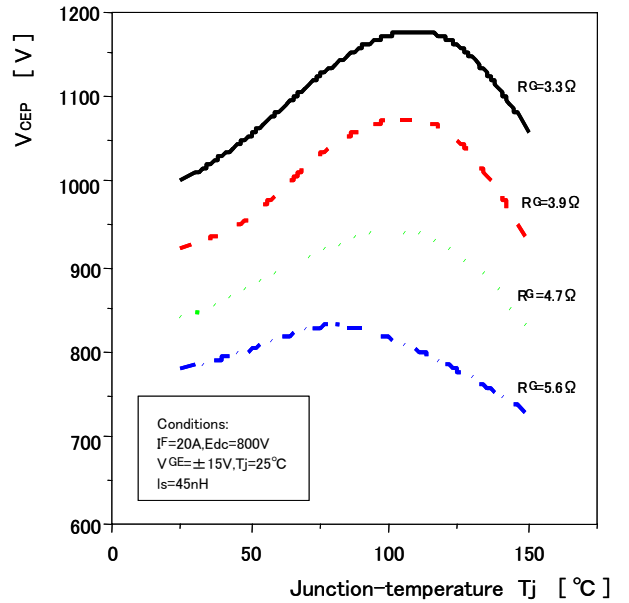
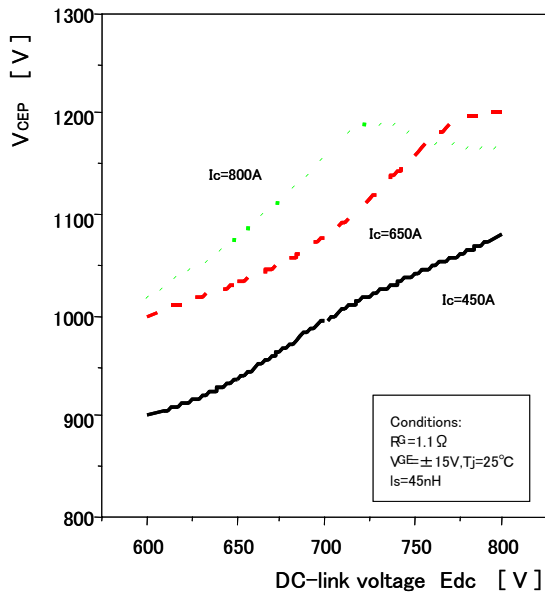
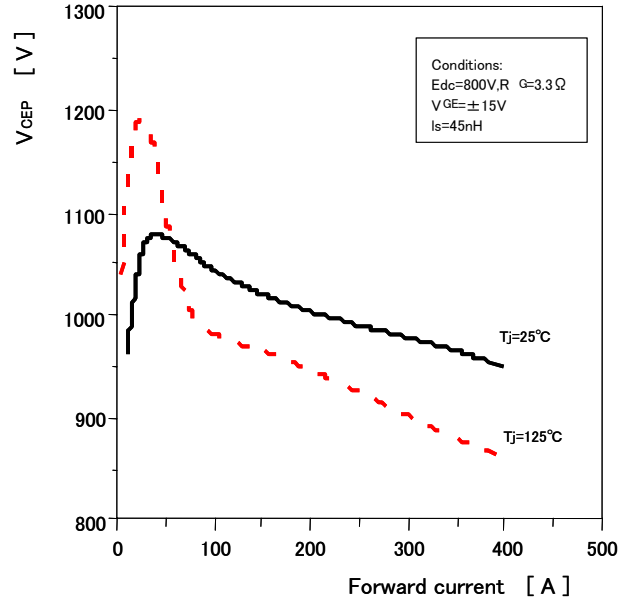
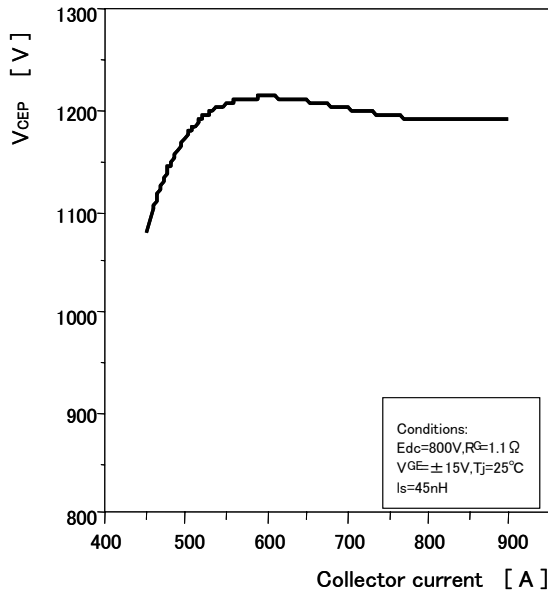

6MBI450U-120

Fig. 5-10 Surge voltage of turn-off

6MBI450U-120

Fig. 5-11 Surge voltage of reverse recovery

## WARNING

1. This Catalog contains the product specifications, characteristics, data, materials, and structures as of February 2004. The contents are subject to change without notice for specification changes or other reasons. When using a product listed in this Catalog, be sure to obtain the latest specifications.
2. All applications described in this Catalog exemplify the use of Fuji's products for your reference only. No right or license, either express or implied, under any patent, copyright, trade secret or other intellectual property right owned by Fuji Electric Device Technology Co., Ltd. is (or shall be deemed) granted. Fuji Electric Device Technology Co., Ltd. makes no representation or warranty, whether express or implied, relating to the infringement or alleged infringement of other's intellectual property rights which may arise from the use of the applications described herein.
3. Although Fuji Electric Device Technology Co., Ltd. is enhancing product quality and reliability, a small percentage of semiconductor products may become faulty. When using Fuji Electric semiconductor products in your equipment, you are requested to take adequate safety measures to prevent the equipment from causing a physical injury, fire, or other problem if any of the products become faulty. It is recommended to make your design fail-safe, flame retardant, and free of malfunction.
4. The products introduced in this Catalog are intended for use in the following electronic and electrical equipment which has normal reliability requirements.
  - Computers
  - OA equipment
  - Communications equipment (terminal devices)
  - Measurement equipment
  - Machine tools
  - Audiovisual equipment
  - Electrical home appliances
  - Personal equipment
  - Industrial robots etc.
5. If you need to use a product in this Catalog for equipment requiring higher reliability than normal, such as for the equipment listed below, it is imperative to contact Fuji Electric Device Technology Co., Ltd. to obtain prior approval. When using these products for such equipment, take adequate measures such as a backup system to prevent the equipment from malfunctioning even if a Fuji's product incorporated in the equipment becomes faulty.
  - Transportation equipment (mounted on cars and ships)
  - Trunk communications equipment
  - Traffic-signal control equipment
  - Gas leakage detectors with an auto-shut-off feature
  - Emergency equipment for responding to disasters and anti-burglary devices
  - Safety devices
6. Do not use products in this Catalog for the equipment requiring strict reliability such as (without limitation)
  - Space equipment
  - Aeronautic equipment
  - Nuclear control equipment
  - Submarine repeater equipment
  - Medical equipment
7. Copyright © 1996-2004 by Fuji Electric Device Technology Co., Ltd. All rights reserved.

No part of this Catalog may be reproduced in any form or by any means without the express permission of Fuji Electric Device Technology Co., Ltd.
8. If you have any question about any portion in this Catalog, ask Fuji Electric Device Technology Co., Ltd. or its sales agents before using the product.

Neither Fuji Electric Device Technology Co., Ltd. nor its agents shall be liable for any injury caused by any use of the products not in accordance with instructions set forth herein.