

CAUTION

THE  MARK INDICATES THE PRIMARY CIRCUIT TO DISTINGUISH THE PRIMARY FROM THE SECONDARY CIRCUIT. PAY ATTENTION NOT TO RECEIVE AN ELECTRIC SHOCK DURING REPAIR AND SERVICE OF THE PRODUCTS.

- NOTE 1.** WHEN MEASURE THE VOLTAGE OR WAVEFORM ON THE POWER TRANSFORMER CIRCUIT. SET THE GND TERMINAL OF MEASURING POINT AS FOLLOWS.
 PRIMARY SIDE..... T1201-(7)
 SECONDARY SIDE..... T1201-(13) or (14)
- NOTE 2.** THE DC VOLTAGE INDICATE IN PRIMARY SIDE IS SHOWN THE VOLTAGE WHEN INPUT AC IN 220V.
- NOTE 3.** THE MEASUREMENT MODE OF THE DC VOLTAGE ON THIS DIAGRAM IS STOP MODE.
- NOTE 4.** DO NOT USE ANY PARTS NUMBER SHOWN ON THIS SCHEMATIC DIAGRAM FOR ORDERING. WHEN YOU ORDER A PART, PLEASE REFER TO PARTS LIST.

A

1

2

3

4

IM
C
S
W
T

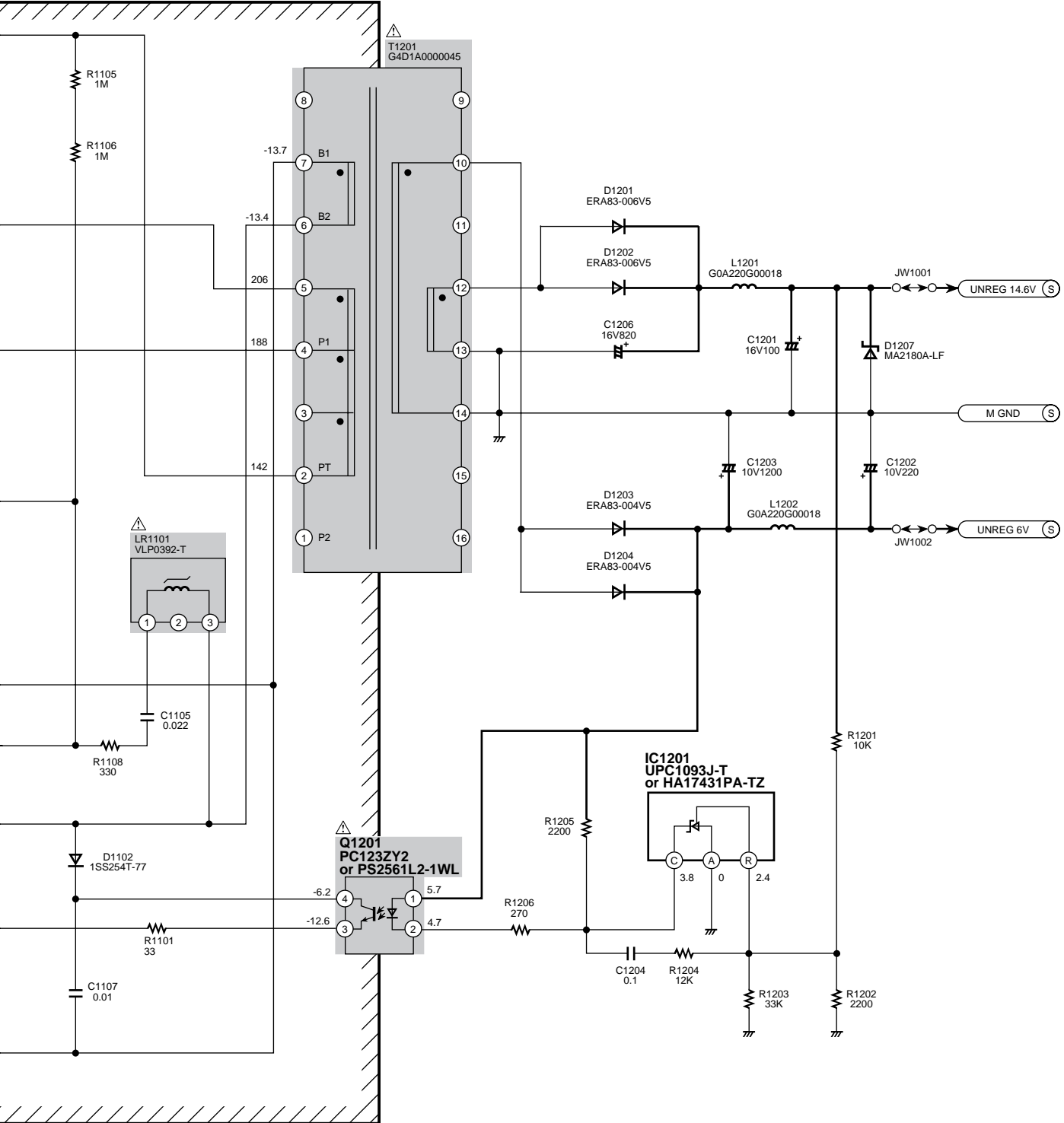

IMPORTANT SAFETY NOTICE:
 COMPONENTS IDENTIFIED WITH THE MARK  HAVE THE
 SPECIAL CHARACTERISTICS FOR SAFETY.
 WHEN REPLACING ANY OF THESE COMPONENTS. USE ONLY
 THE SAME TYPE.

**NV-SJ3MK2AM/PMP, NV-SJ5MK2AM/EU/AU, NV-SJ7AF, NV-FJ8MK2AM
 POWER SECTION IN MAIN SCHEMATIC DIAGRAM**

5

6

7

8

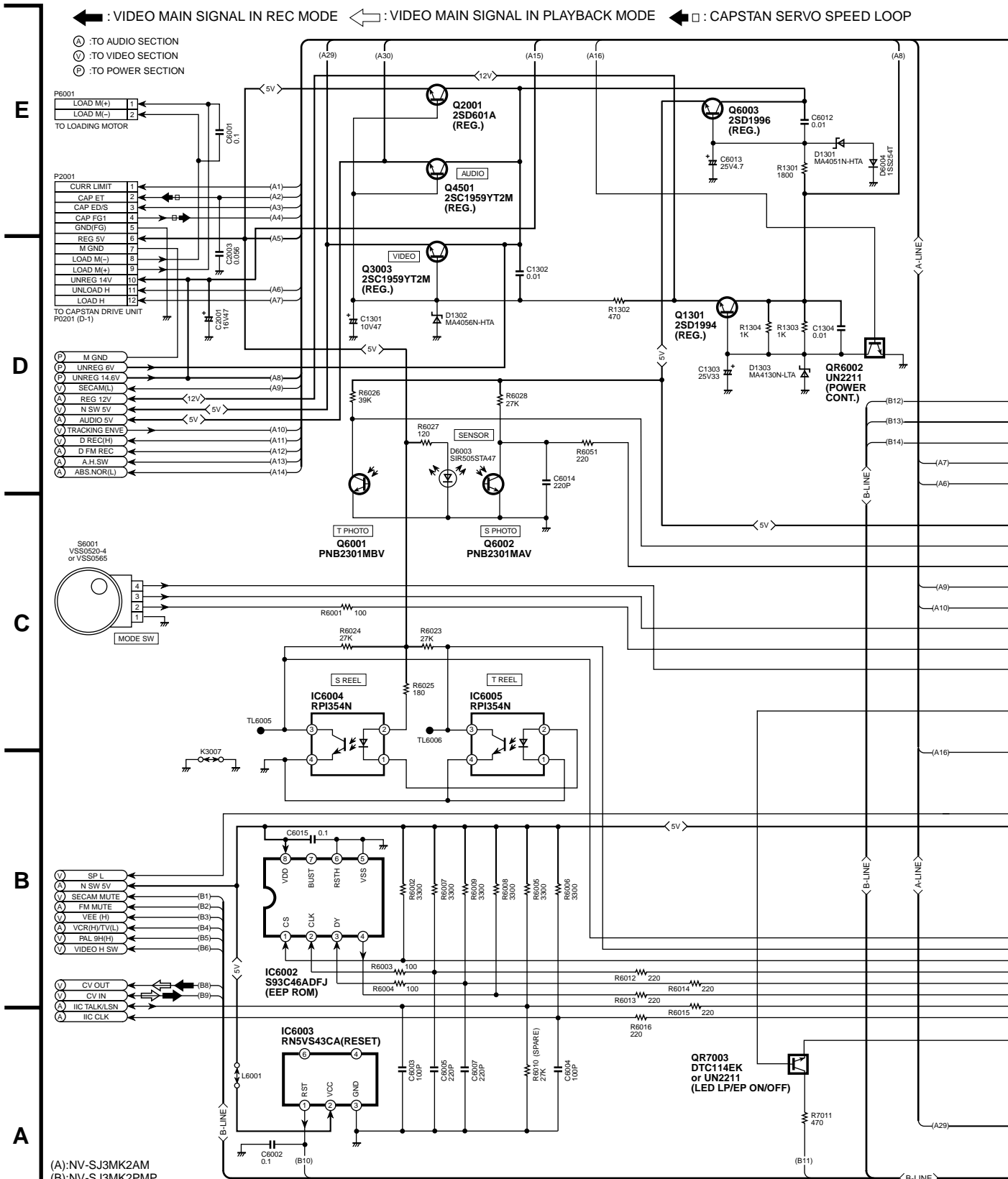

- (A): NV-SJ3MK2AM
- (B): NV-SJ3MK2PMP
- (C): NV-SJ5MK2AM
- (D): NV-SJ7AF
- (E): NV-SJ5MK2AU
- (F): NV-SJ5MK2EU
- (G): NV-FJ8MK2AM

NOTE : DO NOT USE ANY PARTS NUMBER SHOWN ON THIS SCHEMATIC DIAGRAM FOR ORDERING. WHEN YOU ORDER A PART, PLEASE REFER TO PARTS LIST.

◀ ■ : CAPSTAN SERVO PHASE LOOP ◀ ▨ : CYLINDER SERVO SPEED LOOP ◀ ▩ : CYLINDER SERVO PHASE LOOP

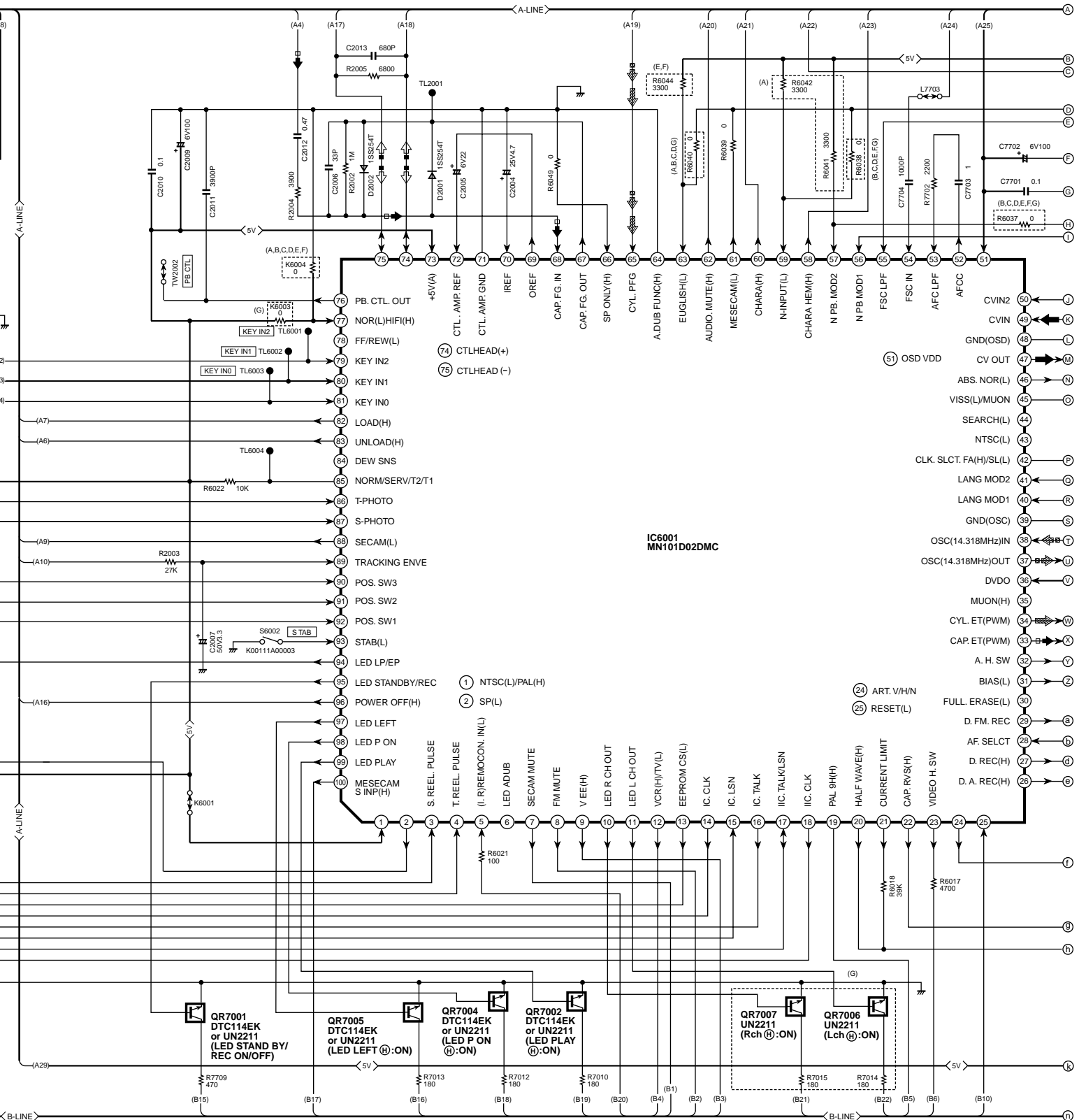

NV-SJ3MK2AM/PMP, NV-SJ5MK2AM/EU/AU, NV-SJ7AF, NV-FJ8MK2AM
SYSTEM CONTROL & SERVO SECTION IN MAIN SCHEMATIC DIAGRAM

4

5

6

7

8

SYSTEM CONTROL & SERVO ICs VOLTAGE CHART (SP MODE)

Ref.No.	IC2501																			
MODE	1	2	3	4	5	6	7	8	9	10	11	12	13	14	15	16	17	18	19	20
STOP	4.3	0	5.0	0.7	5.0	1.1	0	2.4	0	0	1.0	2.6	0.2	1.6	1.6	4.3	14.5	4.3	0	4.3
PLAY	4.3	0	5.0	0	0	0	0	0	0	0	1.0	0	0.2	1.6	1.6	0	14.5	4.3	0	4.3
REC	4.3	0	5.0	1.0	5.0	1.1	1.0	2.4	0	0	1.0	2.6	0.2	1.6	1.6	4.4	14.5	4.4	0	4.3
F.F	4.2	0	5.0	0.8	5.0	1.1	1.0	2.4	0	0	1.0	2.6	0.2	1.6	1.6	4.2	14.5	4.2	0	4.2
REW	4.4	0	5.0	1.0	5.0	1.1	0	0	0	0	1.0	2.6	0.2	1.6	1.6	4.3	14.5	4.4	0	4.5
Ref.No.	IC6001																			
MODE	1	2	3	4	5	6	7	8	9	10	11	12	13	14	15	16	17	18	19	20
STOP	5.0	0	0.1	5.0	5.0	0	0	0.1	5.0	4.9	4.9	5.0	0.3	5.0	5.0	5.0	4.4	4.9	0	0
PLAY	5.0	0	5.0	5.0	5.0	0	0	0.1	0	4.9	4.9	5.0	0.3	5.0	5.0	5.0	4.5	4.5	0	0.3
REC	5.0	0	5.0	5.0	5.0	0	0	0	0	4.9	5.0	0.3	5.0	5.0	5.0	4.4	4.2	0	0.5	0.5
F.F	5.1	0	0.1	2.3	5.0	0.1	0	0.1	5.0	4.9	4.9	0.1	0.3	5.1	5.1	5.1	4.7	4.4	0	4.8
REW	5.1	0	2.4	5.0	5.0	0	0	0.1	5.0	4.9	4.9	5.0	0.3	5.1	5.1	5.1	4.6	4.5	0	4.8
Ref.No.	IC6001																			
MODE	21	22	23	24	25	26	27	28	29	30	31	32	33	34	35	36	37	38	39	40
STOP	0	0	5.0	0	5.0	0	0	0	0	5.0	5.0	0	0	2.4	0.1	5.0	2.5	2.5	0	0
PLAY	4.1	0	5.0	0	5.0	0	0	0	0	5.0	5.0	0.2	2.4	2.4	0.2	5.0	2.5	2.5	0	0
REC	4.1	0	5.0	0	5.0	4.9	5.0	0	4.9	0	0.1	0	2.4	0	0	5.0	0	2.5	0	0
F.F	5.0	0	5.0	0	5.0	0	0	0	0	5.0	5.0	0	5.0	2.4	0.1	5.0	2.5	2.5	0	0
REW	5.0	5.0	1.6	0	5.1	0	0	0	0	5.1	5.0	0	5.0	2.4	0	5.0	2.5	2.5	0	0
Ref.No.	IC6001																			
MODE	41	42	43	44	45	46	47	48	49	50	51	52	53	54	55	56	57	58	59	60
STOP	0	0	0	0	0	4.2	1.8	0	1.8	0.8	4.9	2.3	2.5	0	0	0	0	0	0	0
PLAY	0	0	0	0	0	4.1	1.8	0	1.9	0.8	5.0	2.4	2.5	0.1	0.1	0	0	0	0	0
REC	0	0	0	0	0	4.0	1.8	0	1.8	0.8	4.9	2.2	2.5	0	0	0	0	0	0	0
F.F	0	0	0	0	0	4.2	1.8	0	1.8	0.8	5.0	2.4	2.5	0	0	0	0	0	0	0
REW	0	0	0	0	0	4.2	1.8	0	1.8	0.8	4.9	2.4	2.5	0	0	0	0	0	0	0
Ref.No.	IC6001																			
MODE	61	62	63	64	65	66	67	68	69	70	71	72	73	74	75	76	77	78	79	80
STOP	0	0	0	0	0.7	0	2.4	2.4	2.4	2.4	0	2.4	5.0	2.4	2.4	2.4	5.0	0	5.0	5.0
PLAY	0	0	0	0	0.7	0	2.4	2.4	2.4	2.4	0	0.1	5.0	-	-	2.5	5.0	0	5.0	5.0
REC	0	0	0	0	0.7	0	2.4	2.4	0	2.4	0	2.4	5.0	3.3	1.4	2.4	5.0	0	5.0	5.0
F.F	0	0	0	0	1.0	0	2.4	2.4	2.4	2.4	0	2.4	5.0	2.4	2.4	2.5	5.1	0.1	5.1	5.0
REW	0	0	0	0	0.7	0	2.4	2.4	2.4	2.4	0	2.4	5.0	2.4	2.4	2.5	5.1	0.1	5.1	5.1
Ref.No.	IC6001																			
MODE	81	82	83	84	85	86	87	88	89	90	91	92	93	94	95	96	97	98	99	100
STOP	0.0	0	0	0	5.0	4.5	4.3	0	0	5.0	0	0	0	0	0	0	0	4.9	0	0
PLAY	5.0	0	0	0	5.0	4.4	4.0	0	4.0	5.0	0	0	0	0	0	0	5.0	4.9	4.9	0
REC	5.0	0	0	0	5.0	4.5	4.8	0	0	5.0	0	0	0	0	0	4.9	0	4.9	4.9	0
F.F	5.0	0	0	0	5.0	4.8	4.4	0	3.6	5.0	5.0	0	0	0	5.0	0	5.0	4.9	4.9	0
REW	5.1	0	0	0	5.1	4.5	4.6	0	3.9	5.0	5.0	0	0	0	5.0	0	5.0	4.9	4.9	0
Ref.No.	IC6002					IC6003					IC6004									
MODE	1	2	3	4	5	6	7	8	1	2	3	4	5	1	2	3	4			
STOP	0.3	5.0	5.0	5.0	0	0	0	5.0	5.0	5.0	0	0	0	1.0	2.2	5.0	0			
PLAY	0.3	5.0	5.0	5.0	0	0	0	5.0	5.0	5.0	0	0	0	1.0	2.2	5.0	0			
REC	0.3	5.0	5.0	5.0	0	0	0	5.0	5.0	5.0	0	0	0	1.0	2.2	5.0	0			
F.F	0.3	5.0	5.0	5.0	0	0	0	5.1	5.0	5.0	0	0	0	1.1	2.2	2.5	0			
REW	0.3	5.1	5.1	5.1	0	0	0	5.1	5.1	5.1	0	0	0	1.1	2.2	2.5	0			
Ref.No.	IC6005																			
MODE	1	2	3	4																
STOP	0	1.0	5.0	0																
PLAY	0	1.0	5.0	0																
REC	0	1.0	5.0	0																
F.F	0	1.0	2.2	0																
REW	0	1.0	2.3	0																

SYSTEM CONTROL & SERVO TRANSISTORS VOLTAGE CHART (SP MODE)

Ref.No.	Q1301			Q2001			Q3003			Q4001			Q4002			Q4003				
MODE	E	C	B	E	C	B	E	C	B	E	C	B	E	C	B	E	C	B		
STOP	12.1	14.5	12.7	5.0	5.7	5.7	5.0	5.7	5.7	0	0	0.6	0	0	0.6	0	0.8	0	0.2	0.2
PLAY	12.1	14.5	12.7	5.0	5.8	5.7	5.0	5.8	5.7	0	0	0.6	0	0	0.6	0	0.3	0.3		
REC	0	12.7	0	5.0	5.7	5.7	5.0	5.7	5.7	-19.9	0	-28.9	-19.9	0	-28.4	0	4.5	0.8		
F.F	12.1	14.5	12.7	5.0	6.1	5.8	5.0	6.2	5.7	0	0	0.6	0	0	0.6	0	0.2	0.2		
REW	12.1	14.5	12.7	5.0	5.9	5.8	5.0	6.1	5.7	0	0	0.6	0	0	0.6	0	0.2	0.2		
Ref.No.	Q4004			Q4501			Q6001			Q6002			Q6003			Q7702				
MODE	E	C	B	E	C	B	+	-		+	-		E	C	B	E	C	B		
STOP	5.0	0.2	4.2	5.0	5.7	5.8	4.4	0		4.9	0		5.0	5.7	5.7	0.8	0	0		
PLAY	5.0	0.3	5.0	5.0	5.8	5.8	4.2	0		4.6	0		5.0	5.8	5.7	0.8	0	0		
REC	4.9	4.8	4.2	5.0	5.7	5.7	4.5	0		4.7	0		5.0	5.7	5.7	0.8	0.1	0		
F.F	5.0	0.2	5.0	5.0	6.2	5.8	4.7	0		4.7	0		5.1	6.1	5.7	0.8	0.2	0		
REW	5.0	0.2	5.0	5.0	6.2	5.8	4.8	0		4.8	0		5.1	6.0	5.7	0.8	0	0		
Ref.No.	Q7703			Q7704			Q7705													
MODE	S	D	G	S	D	G	S	D	G											
STOP	0.8	1.8	0	0.8	4.9	0	0.8	4.9	0											
PLAY	0.8	1.8	0	0.8	4.9	0	0.8	4.9	0											
REC	0.8	1.8	0	0.8	4.9	0	0.8	4.9	0											
F.F	0.8	1.8	0	0.8	5.0	0	0.8	5.0	0											
REW	0.8	1.8	0	0.8	5.0	0	0.8	5.0	0											
Ref.No.	QR4005			QR6002			QR7001			QR7002			QR7003			QR7004				
MODE	E	C	B	E	C	B	E	C	B	E	C	B	E	C	B	E	C	B		
STOP	5.0	5.0	0	0	12.7	0	0	3.8	0	0	0	4.9	0	3.8	0	0	0	4.9		
PLAY	5.0	5.0	0	0	12.7	0	0	3.8	0	0	0	4.9	0	3.8	0	0	0	4.9		
REC	4.9	-28.5	4.9	0	12.7	0	0	0	4.9	0	0	4.9	0	3.8	0	0	0	4.9		
F.F	5.0	5.0	0	0	12.7	0	0	3.8	5.0	0	3.6	4.9	0	3.8	5.0	0	3.6	4.9		
REW	5.0	5.0	0	0	12.7	0	0	3.8	5.0	0	3.6	4.9	0	3.8	5.0	0	3.6	4.9		
Ref.No.	QR7005			QR7006			QR7007													
MODE	E	C	B	E	C	B	E	C	B											
STOP	0	3.6	0	0	0	4.9	0	0	4.9											
PLAY	0	0	5.0	0	0	4.9	0	0	4.9											
REC	0	0	4.9	0	0	4.9	0	0	4.9											
F.F	0	3.6	0	0	0	4.9	0	0	4.9											
REW	0	3.6	5.0	0	0	4.9	0	0	4.9											

NV-SJ3MK2AM/PMP,NV-SJ5MK2AM/EU/AU,NV-SJ7AF,NV-FJ8MK2AM
SYSTEM CONTROL & SERVO SECTION IN MAIN SCHEMATIC DIAGRAM

(S) :TO SYSTEM CONTROL & SERVO SECTION
 (A) :TO AUDIO SECTION

E
 D
 C
 B
 A

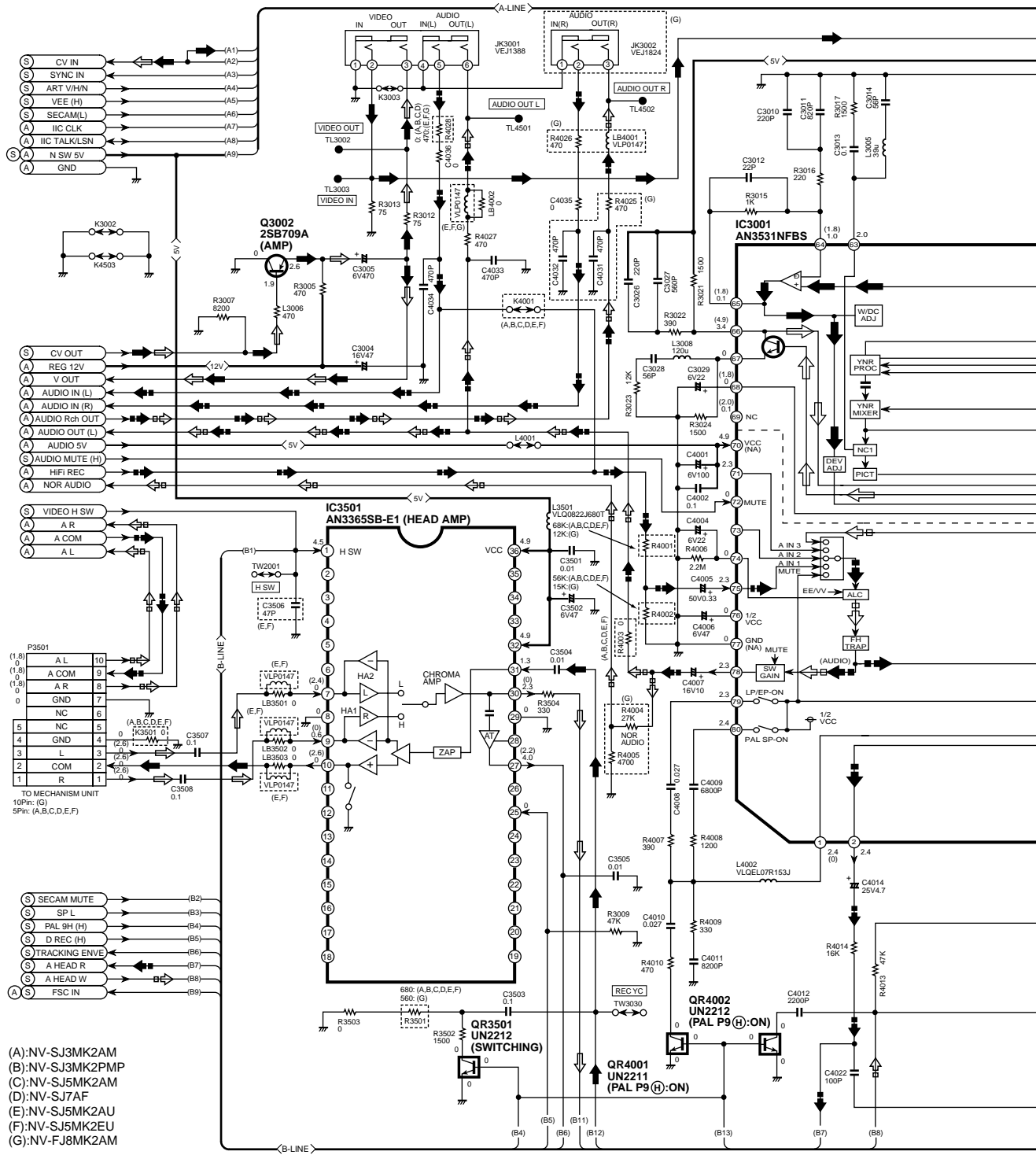

- (A):NV-SJ3MK2AM
- (B):NV-SJ3MK2PMP
- (C):NV-SJ5MK2AM
- (D):NV-SJ7AF
- (E):NV-SJ5MK2AU
- (F):NV-SJ5MK2EU
- (G):NV-FJ8MK2AM

NOTE : DO NOT USE ANY PARTS NUMBER SHOWN ON THIS SCHEMATIC DIAGRAM FOR ORDERING. WHEN YOU ORDER A PART, PLEASE REFER TO PARTS LIST.

NOTE : THE MEASUREMENT MODE OF THE DC VOLTAGE IN THE BRACKETS () ON THIS DIAGRAM IS RECORD MODE WITH PAL COLOUR SIGNAL. (SP MODE) THE MEASUREMENT MODE OF THE DC VOLTAGE OUT OF THE BRACKETS ON THIS DIAGRAM IS PLAYBACK MODE WITH PAL COLOUR SIGNAL. (SP MODE)

1 2 3 4

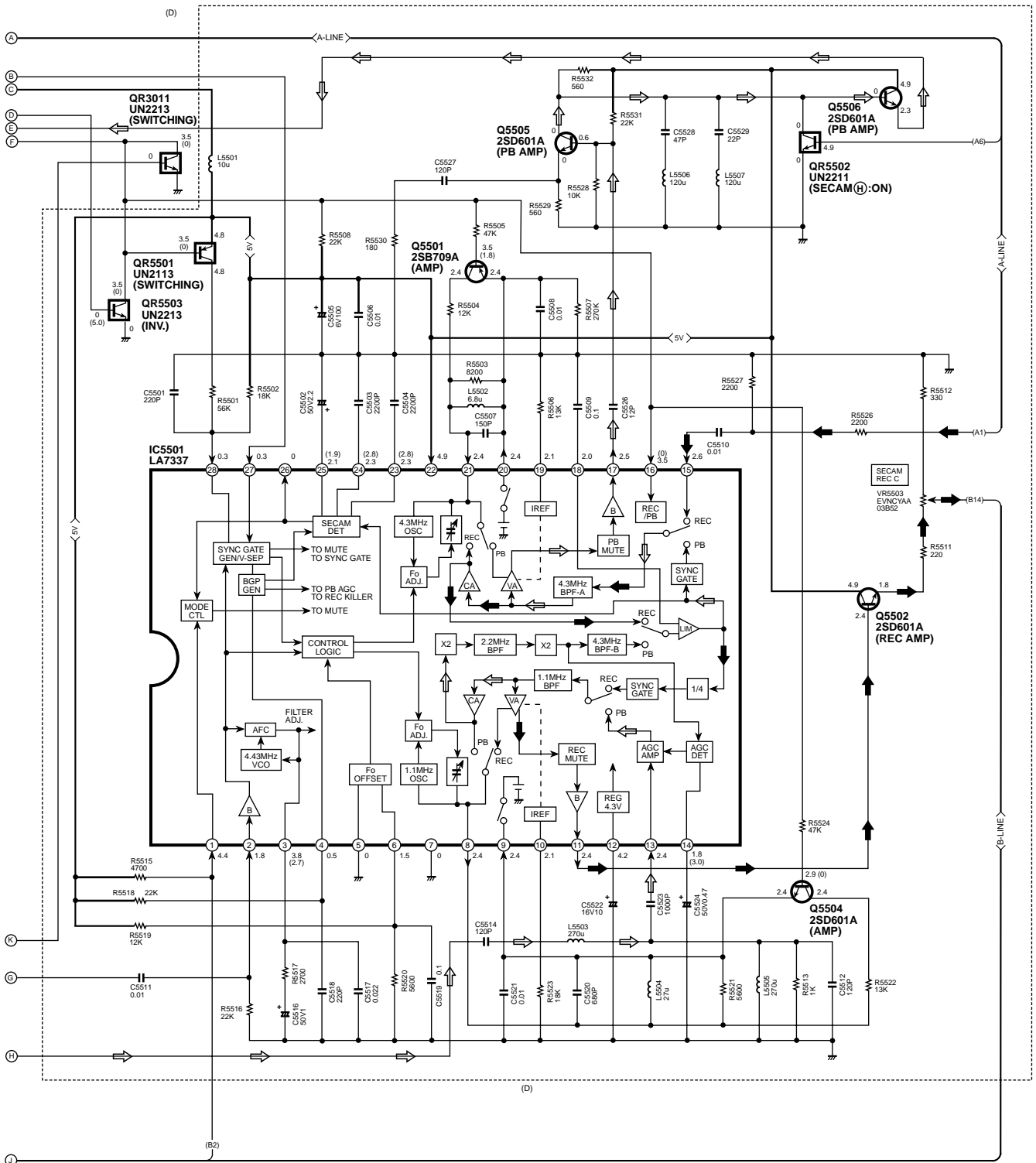

(D):NV-SJ7AF

NV-SJ3MK2AM/PMP,NV-SJ5MK2AM/EU/AU,NV-SJ7AF,NV-FJ8MK2AM
VIDEO SECTION IN MAIN SCHEMATIC DIAGRAM

9

10

11

12

← :CYLINDER SERVO SPEED LOOP

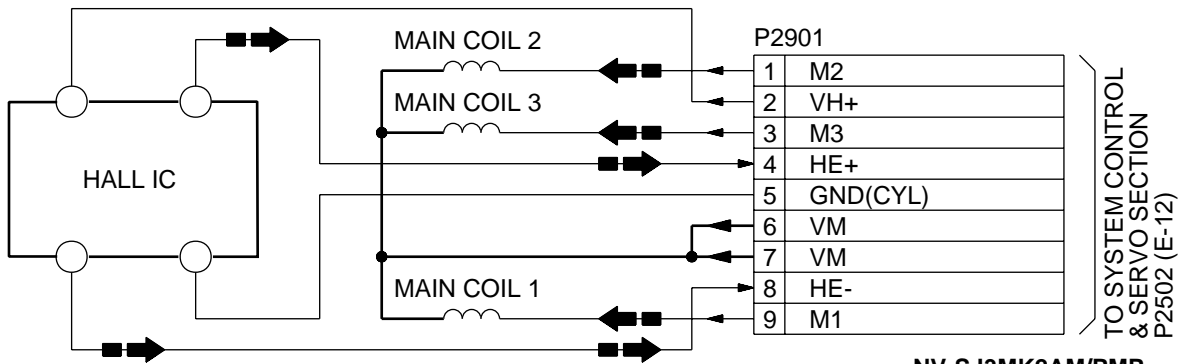

NOTE: DO NOT USE ANY PART NUMBER SHOWN ON THIS SCHEMATIC DIAGRAM FOR ORDERING. WHEN YOU ORDER A PART, PLEASE REFER TO PARTS LIST.

NV-SJ3MK2AM/PMP
 NV-SJ5MK2AM/EU/AU
 NV-SJ7AF,NV-FJ8MK2AM

CYLINDER MOTOR UNIT SCHEMATIC DIAGRAM

A

1

2

3

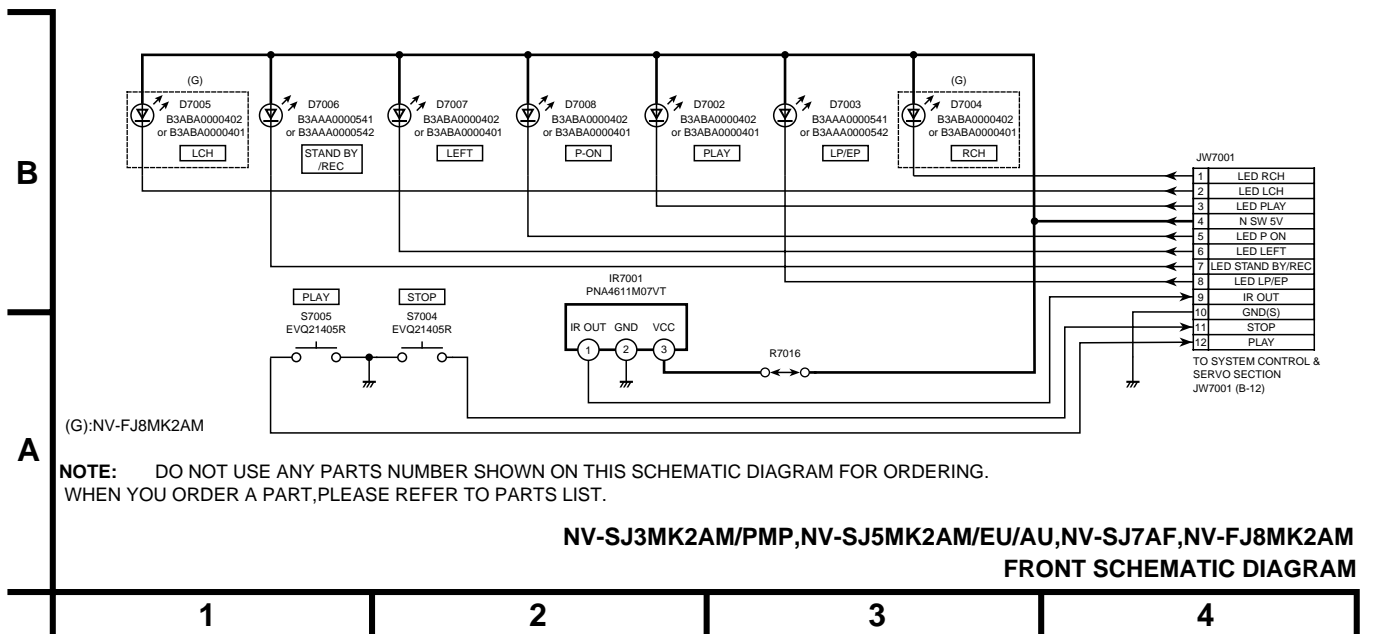

E
D
C
B
A

(S) :TO SYSTEM CONTROL & SERVO SECTION
(V) :TO VIDEO SECTION

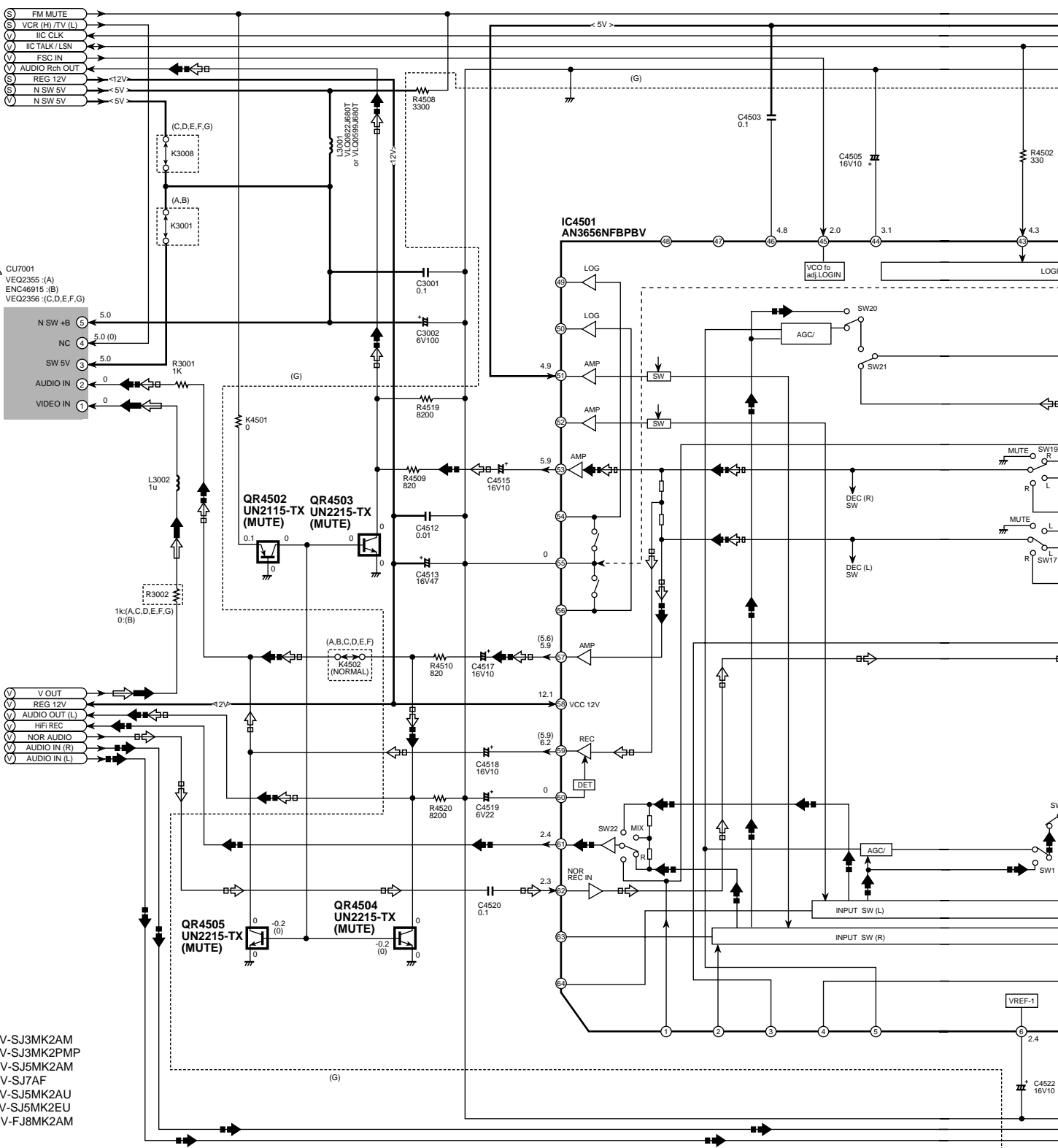

- (A):NV-SJ3MK2AM
- (B):NV-SJ3MK2PMP
- (C):NV-SJ5MK2AM
- (D):NV-SJ7AF
- (E):NV-SJ5MK2AU
- (F):NV-SJ5MK2EU
- (G):NV-FJ8MK2AM

NOTE : THE MEASUREMENT MODE OF THE DC VOLTAGE IN THE BRACKETS () ON THIS DIAGRAM IS RECORD MODE WITH NTSC COLOUR SIGNAL. (SP MODE) THE MEASUREMENT MODE OF THE DC VOLTAGE OUT OF THE BRACKETS ON THIS DIAGRAM IS PLAYBACK MODE WITH NTSC COLOUR SIGNAL. (SP MODE)

IMPORTANT SAFETY NOTICE:
COMPONENTS IDENTIFIED WITH THE MARK Δ HAVE THE SPECIAL CHARACTERISTICS FOR SAFETY. WHEN REPLACING ANY OF THESE COMPONENTS USE ONLY THE SAME TYPE.

← : VIDEO MAIN SIGNAL PATH IN REC MODE ⇐ : VIDEO MAIN SIGNAL PATH IN PLAYBACK MODE
 ⇐ : AUDIO MAIN SIGNAL PATH IN REC MODE ⇐ : AUDIO MAIN SIGNAL PATH IN PLAYBACK MODE

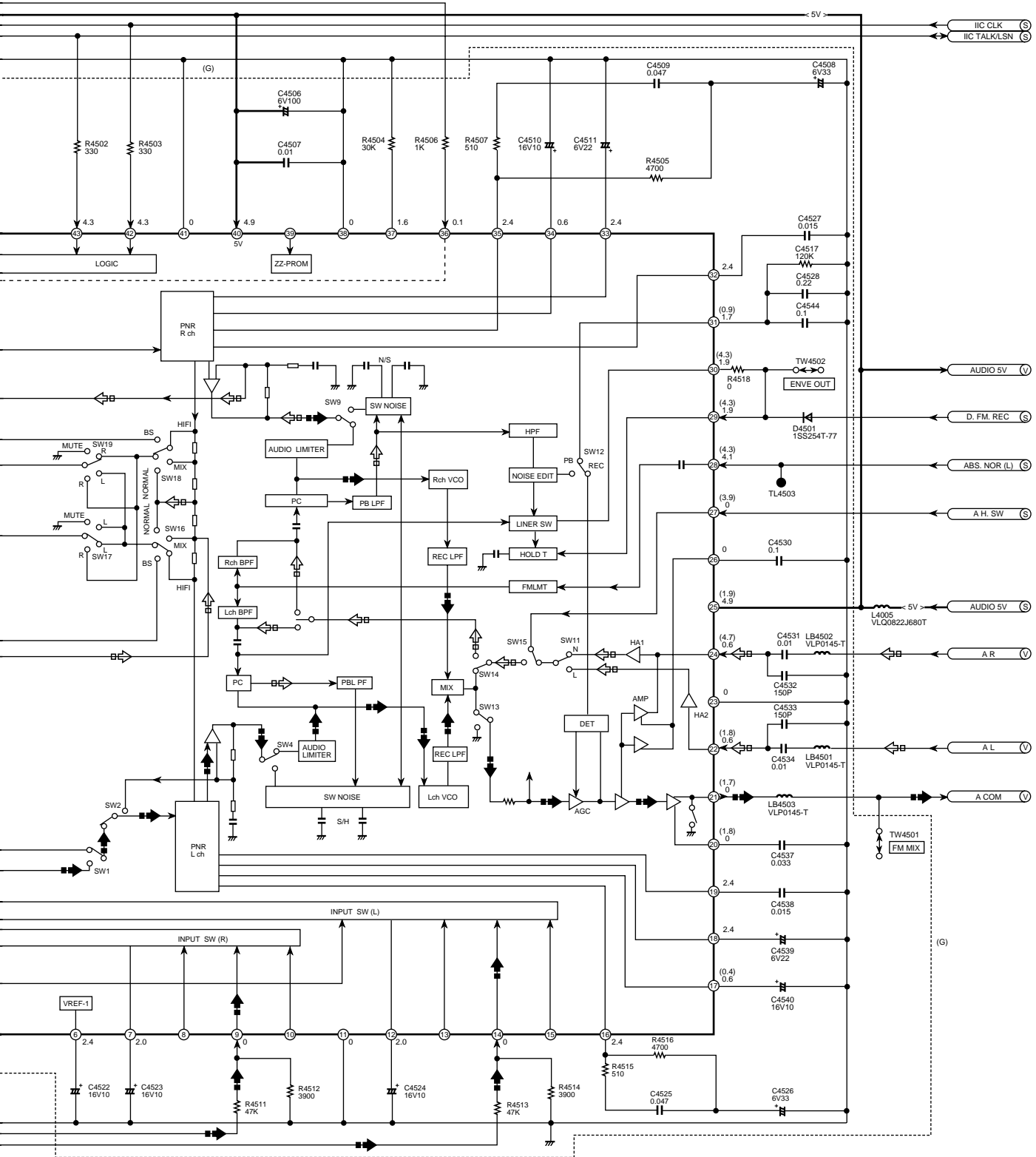

NOTE : DO NOT USE ANY PARTS NUMBER SHOWN ON THIS SCHEMATIC
 DIAGRAM FOR ORDERING.
 WHEN YOU ORDER A PART, PLEASE REFER TO PARTS LIST.

NV-SJ3MK2AMPMP
NV-SJ5MK2AM/EU/AU
NV-SJ7AF,NV-FJ8MK2AM

AUDIO SECTION IN MAIN SCHEMATIC DIAGRAM

5

6

7

8

E

D

C

B

A

TO SYSTEM CONTROL & SERVO SECTION P2001 (E-1)

P0201	
CURR LIMIT	1
CAP ET	2
CAP ED/S	3
CAP FG1	4
GND(FG)	5
REG 5V	6
GND(MOTOR)	7
LOAD MOTOR(-)	8
LOAD MOTOR(+)	9
UNREG 14V	10
UNLOADING (H)	11
LOADING (H)	12

R0206 (FG HEAD)

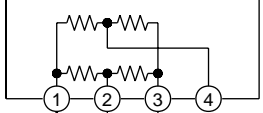

R0207 (HOLE SENSOR H3)

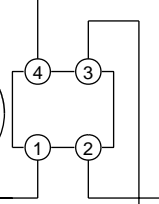

R0208 (HOLE SENSOR H1)

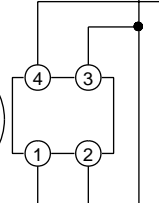

R0209 (HOLE SENSOR H2)

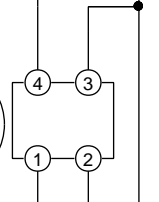

C0201

R0201

R0211

C0206

C0207

IC020 (CAPSTA)

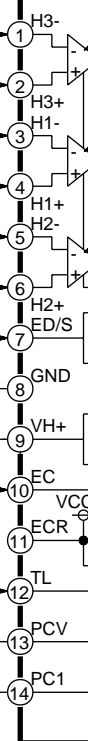

1

2

3

4

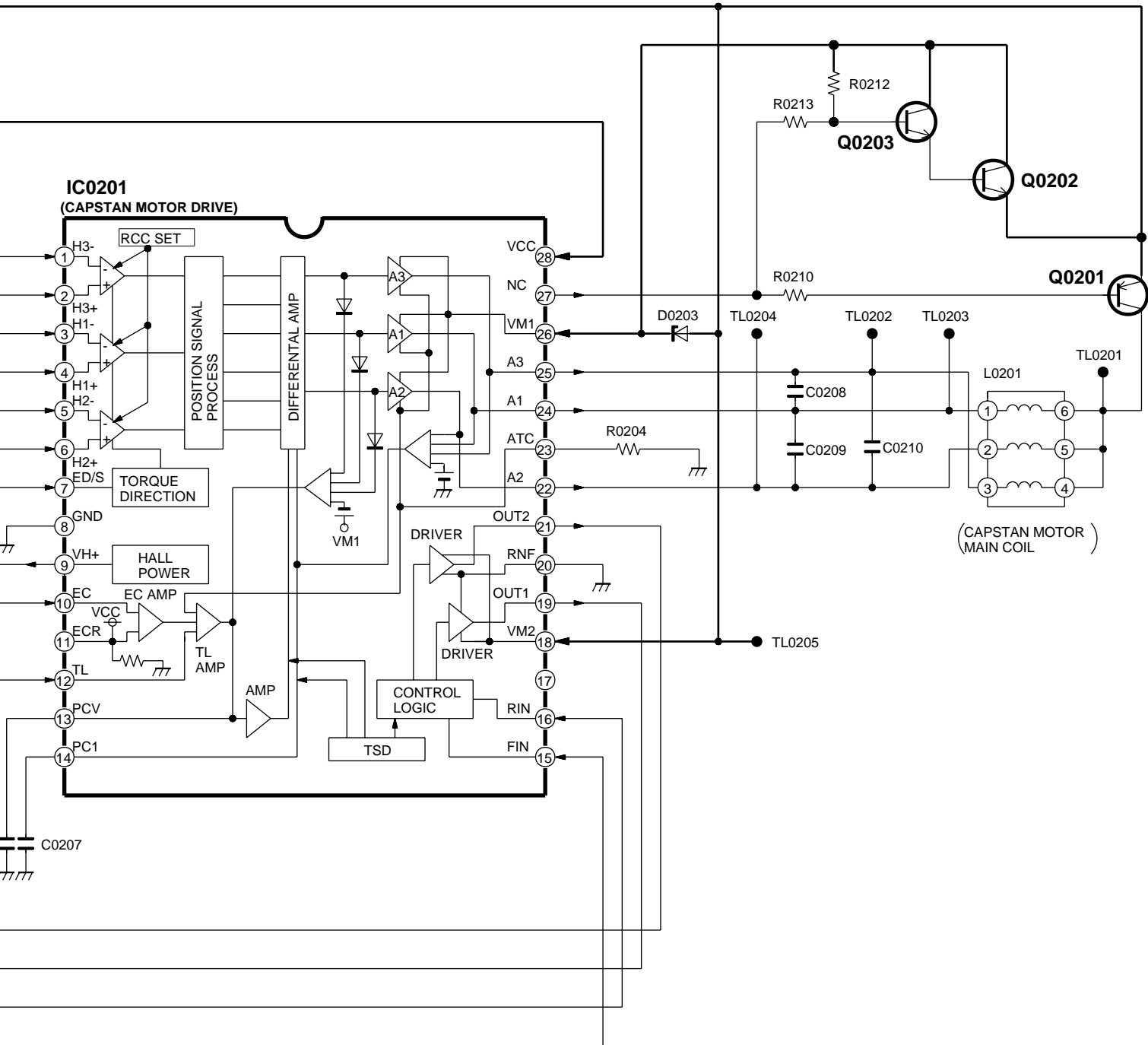

NV-SJ3MK2AM/PMP,NV-SJ5MK2AM/EU/AU,NV-SJ7AF,NV-FJ8MK2AM
CAPSTAN DRIVE UNIT SCHEMATIC DIAGRAM