

POWER CIRCUIT DIAGRAM

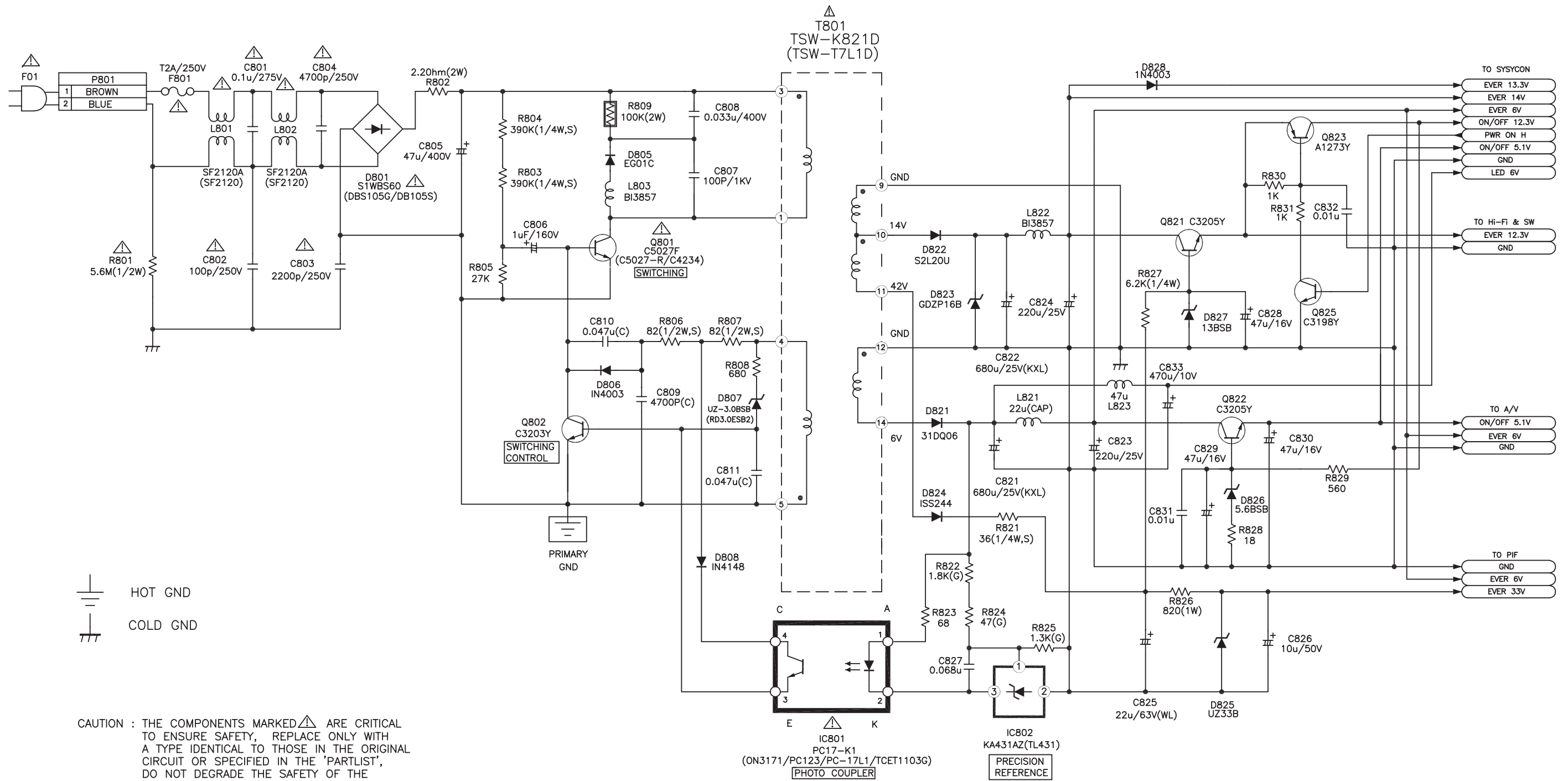

proveri ovo dali radi